

La Cornue

— 1908 2008 —



La Cornue 1908

Installation, operation and maintenance MANUAL

CHÂTEAU SERIES

RANGES & COOKTOPS « Centenaire »

GRAND PALAIS 180

CHÂTEAU 165

CHÂTEAU 150

CHÂTEAU 120

CHÂTEAU 90

CHÂTEAU 75

GAS-FIRED



LISTED

ANSI/CGA Standard
Designation
85KJ



WARNING: IF THE INFORMATION ON THIS MANUAL IS NOT FOLLOWED EXACTLY, A FIRE OR EXPLOSION MAY RESULT CAUSING PROPERTY DAMAGE, PERSONAL INJURY OR DEATH.

- Do not store or use gasoline or other flammable vapors or liquids in the vicinity of this or any other appliance.
- **WHAT TO DO IF YOU SMELL GAS**
 - Do not try to light any appliance.
 - Do not touch any electrical switch.
 - Do not use any phone in your building.
 - Immediately call your gas supplier from a neighbor's phone. Follow the gas supplier's instructions.
 - If you cannot reach your gas supplier, call the fire department.
- Installation and service must be performed by a qualified installer, service agency or the gas supplier.

WARNING

(Only for the models Château 90 & Château 75)

THE ANTI-TIP DEVICE SUPPLIED WITH THE RANGES CHATEAU 90 & CHATEAU 75 MUST BE CORRECTLY FITTED WHEN THE APPLIANCE IS INSTALLED. THIS WILL REDUCE RISK OF TIPPING OF THE APPLIANCE FROM ABNORMAL USAGE OR BY EXCESSIVE LOADING OF THE OVEN DOOR.



WARNING

- ALL RANGES CAN TIP
- INJURY TO PERSONS COULD RESULT
- INSTALL ANTI-TIP BRACKET PACKED WITH RANGE
- SEE INSTALLATION INSTRUCTIONS

CAUTION

DO NOT STORE ITEMS OF INTEREST TO CHILDREN IN CABINETS ABOVE A RANGE OR ON THE BACKGUARD OF A RANGE - CHILDREN CLIMBING ON THE RANGE TO REACH ITEMS COULD BE SERIOUSLY INJURED.

IMPORTANT SAFETY INSTRUCTIONS

This book contains many important safety messages.
Always read and obey all safety messages.
Installer: Leave these instructions with the appliance



WARNING: NEVER use this appliance as a space heater to heat or warm the room. Doing so may result in carbon monoxide poisoning and overheating of the oven



WARNING: NEVER cover any slots, holes or passages in the oven bottom or cover an entire rack with materials such as aluminum foil. Doing so blocks airflow through the oven and may cause carbon monoxide poisoning. Do not use aluminum foil to line surface unit drip bowls or oven bottoms, except as suggested in the manual. Improper installation of these liners may result in a risk of electric shock, or fire.

- ◆ **Proper Installation** - Be sure your appliance is properly installed and grounded by a qualified technician.

The installation of your La Cornue appliance must conform with local codes or, in the absence of local codes, in the USA with the "National Fuel Gas Code", ANSI Z223.1NFPA 54, latest edition, and, in Canada, with CAN/CGA - B149.1, and CAN CGA - B149.2, "Installation Code for Gas Burning Appliances".

The appliance must be electrically installed and grounded in accordance with local codes or in the absence of such codes with the latest edition of the "National Electrical Code", ANSI/NFPA 70 in the USA, and CSA C22.2 "Canadian Electrical Code" - in Canada.

Important - Save the installation instructions for the local electrical inspector's use.

IMPORTANT SAFETY INSTRUCTIONS



In Case of Fire

Do not use water on grease fires. Never pick up a flaming pan. Turn the controls off. Smother a flaming pan on a cooktop burner by covering the pan completely with a well fitting lid or baking tray. If available use a multipurpose dry chemical or foam-type fire extinguisher.

If fire is in an oven pan, smother by closing oven door. Open doors and windows or if a hood is fitted turn it on to remove smoke and odor.

To Prevent Fire or Smoke Damage

Before using the range make sure all the packing materials have been removed. Always keep the area around the range free from combustible materials, gasoline, and other flammable vapors and liquids.

If the range is installed near a window, proper precautions should be taken to prevent curtains from blowing over the burners.

NEVER leave any items on the range cooktop. The hot air from an oven vent may ignite flammable items and may increase pressure in closed containers, which may cause them to burst. Many aerosol-type spray cans are **EXPLOSIVE** when exposed to heat and may be highly flammable. Avoid their use or storage near an appliance.

Many plastics will burn and most are damaged by heat. Keep plastic items away from parts of the range that may become warm or hot. Do not leave plastic items on the cooktop as they may burn, melt or soften if left too close to a vent or a lighted burner

IMPORTANT SAFETY INSTRUCTIONS

- ◆ Purchaser of this appliance must post in a prominent location instructions to be followed in the event the user smells gas. This information shall be obtained by consulting your local gas supply company.
- ◆ Keep appliance area free and clear from combustibles.
- ◆ It is essential that the kitchen where your appliance will be installed has excellent ventilation to the outside for steam and combustion gases removal.
- ◆ Do not use air recycling systems.
- ◆ “La Cornue” can provide customers with hoods in materials matching the appliance. The hoods are sold without blower systems since every installation is unique. The individual requirements are best handled by a professional ventilation specialist.
- ◆ Adequate clearance must be provided for air openings into the combustion chamber.
- ◆ Minimum clearances to combustible construction see item 1.2. page 27.
- ◆ Adequate clearance must be provided for proper operation and servicing of the appliance.
- ◆ A manual valve must be installed in an accessible location in the gas piping external to the appliance for the purpose of turning on or shutting off gas to the appliance.
- ◆ The range and its individual shutoff valve must be disconnected from the gas supply piping system during any pressure testing of that system at test pressures in excess of 1/2 psig (3.5 kPa).
- ◆ The appliance must be isolated from the gas supply piping system by closing its individual manual shutoff valve during any pressure testing of the gas supply piping system at test pressures equal to or less than 1/2 psig (3.5 kPa).

IMPORTANT SAFETY INSTRUCTIONS

- ◆ Leak testing of the appliance shall be conducted according to the manufacturer's instructions.
- ◆ The inlet gas supply pressure to the appliance must be within the following limits

Type of gas	Inlet pressure		Manifold pressure
Natural gas	10" WC maximum (2.49 kPa)	6" WC minimum (1.49 kPa)	5" WC (1.24 kPa)
Propane gas	13" WC maximum (3.24 kPa)	12" WC minimum (2.99 kPa)	11" WC (2.74 kPa)

- ◆ **Keep this manual for future reference.**
- ◆ **Do Not Leave Children Alone** - Children should not be left alone or unattended in area where appliance is in use. They should never be allowed to sit or stand on any part of the appliance.
Do not allow children to climb or play around the range. The weight of a child on an open door may cause the range to tip, resulting in serious burns or other injury.
Teach them not to play with controls or any other part of the range.
Destroy the carton and plastic bags after unpacking the range. Never allow children to play with packaging material.
- ◆ **Wear Proper Apparel** - Loose-fitting or hanging garments should never be worn while using the appliance.
- ◆ **User Servicing** - Do not repair or replace any part of the appliance unless specifically recommended in the manual. All other servicing should be referred to a qualified technician.
- ◆ **Use Proper Pan Size** - This appliance is equipped with more surface units of different size. Select utensils having flat bottoms large enough to cover the surface unit heating element. The use of undersized utensils will expose a portion of the heating element to direct contact and may result in ignition of clothing. Proper relationship of utensil to burner will also improve efficiency.

IMPORTANT SAFETY INSTRUCTIONS

- ◆ **The top burner flame size** should be adjusted so it does not extend beyond the edge of the cooking utensil. This instruction is based on safety considerations.
- ◆ **Use Only Dry Potholders or Oven Gloves** - Moist or damp potholders on hot surfaces may result in burns from steam. Never let a potholder touch hot heating elements.
Do not use a towel or other bulky cloth in place of a glove. They might catch fire if they touch a hot surface.
Use dry oven gloves when applicable - using damp gloves might result in steam burns when you touch a hot surface. Never operate the range with wet hands.
- ◆ **Never Leave Surface Units Unattended at High Heat Settings** - Boll over causes smoking and greasy spillovers that may ignite.
- ◆ **Make Sure Reflector Pans or Drip Bowls Are in Place** - Absence of these pans or bowls during cooking may subject wiring or components underneath to damage.
- ◆ **Glazed Cooking Utensils** - Only certain types of glass, glass/ceramic, ceramic, earthenware, or other glazed utensils are suitable for range-top service without breaking due to the sudden change in temperature.
- ◆ **Utensil Handles Should Be Turned Inward and Not Extend Over Adjacent Surface Units** - To reduce the risk of burns, ignition of flammable materials, and spillage due to unintentional contact with the utensil, the handle of a utensil should be positioned so that it is turned inward, and does not extend over adjacent surface units.
- ◆ **Do Not Soak Removable Heating Elements** - Heating elements should never be immersed in water.
- ◆ **Use Care When Opening Door** - Let hot air or steam escape before removing or replacing food.

IMPORTANT SAFETY INSTRUCTIONS

- ◆ **Do Not Heat Unopened food Containers** - Build-up of pressure may cause container to burst and result in injury.
- ◆ **Do not use the oven for storage** - This instruction is based on safety considerations. Flammable materials should not be stored in an oven, the range storage drawer or near the cooktop burners. This includes paper, plastic and cloth items, such as cookbooks, plasticware and towels, as well as flammable liquids. Do not store explosives, such as aerosol cans, on or near the appliance.
Flammable materials may explode and result in fire or property damage.
- ◆ **Keep oven vent ducts unobstructed.**
- ◆ **Placement of Oven Racks** - Always place oven racks in desired location while oven is cool. If rack must be moved while oven is hot, do not let potholder contact hot heating element in oven.
- ◆ **To avoid personal injury, do not sit, stand or lean on oven doors or drawer.**
Leaning, sitting or stepping on the doors or drawer of this range can result in serious injuries and also cause damage to the range. Do not allow anyone to climb, stand or hang on any part of the range.
- ◆ **Wear Suitable Clothing** - Never wear loose-fitting or hanging clothes while using the range. Be careful when reaching for items stored in cabinets over the cooktop. Flammable material could be ignited if brought in contact with a burner flame or hot surface and may cause severe burns.
- ◆ **Important Safety Notice and Warning** - The California Safe Drinking Water and Toxic Enforcement Act of 1986 (Proposition 65) requires the Governor of California to publish a list of substances known to the State of California to cause cancer or reproductive harm, and requires businesses to warn customers of potential exposures to such substances.

This appliance contains or produces a chemical or chemicals which can cause death or serious illness and which are known to the state of California to cause cancer, birth defects or other reproductive harm.

IMPORTANT SAFETY INSTRUCTIONS

Users of this appliance are hereby warned that the burning of gas can result in low-level exposure to some of the listed substances, including benzene, formaldehyde and soot, due primarily to the incomplete combustion of natural gas or liquid petroleum (LP) fuels. Properly adjusted burners will minimize incomplete combustion.

Exposure to these substances can also be minimized by properly venting with an open window or using a ventilation fan or hood.

To reduce the risk from substances in the fuel or from fuel combustion make sure this appliance is installed, operated, and maintained according to the instructions in this booklet.

- ◆ **Quality of Flames** - On Natural Gas the burners' flames should be a blueish color with, at most, a slight yellowish fringe. On Propane gas the flames may be "softer". The cooktop burner flames may have a slight yellowish tip.

If the flame burns with a long white tip you should call for service.

MAKE SURE THE FLOW OF COMBUSTION AND VENTILATION AIR TO THE RANGE IS UNOBSTRUCTED.

DO NOT TOUCH SURFACE UNITS, AREAS NEAR UNITS, HEATING ELEMENTS OR INTERIOR SURFACES OF OVEN - Surface units and heating elements may be hot even though they are dark in color. Areas near surface units and interior surfaces of an oven may become hot enough to cause burns.

During and after use, do not touch, or let clothing or other flammable materials contact surface units, areas near units, heating elements or interior surfaces of oven until they have had sufficient time to cool. Other surface of the appliance may become hot enough to cause burns - among these surfaces are oven vent openings and surface near these openings, oven doors, etc.

IMPORTANT: Never keep pet birds in the kitchen or in rooms where the fumes from the kitchen could reach. Birds have a very sensitive respiratory system. Fumes released due to overheated cooking oil, fat, margarine and overheated non-stick cookware may be harmful.

You can find this manual on following web sites:

www.lacornueusa.com or www.purcellmurray.com



LE CHÂTEAU 150

Dear Customer,

Thank you for choosing the La Cornue cooking product. We hope that you will derive a lot of enjoyment from cooking delicious meals with it.

The aim of this document is to make you familiar with the potential provided by a professional quality product designed for discriminating individuals, and to facilitate its maintenance.

Above all, a La Cornue product is manufactured using noble and pure materials. The choices made for some components, such as brass for the burners and cast-iron for the gas simmering plate, are the result of criteria of technicality and professional performance, which are not attainable with other materials or protective treatments. We are very much attached to the authenticity of our stoves and we are convinced that you will appreciate them even more as you use them.

In order to make sure that you will be satisfied with your product for a long time, we recommend that you follow the advice given in this manual.

*Thank you for choosing us,
Kind regards,*

Xavier Dupuy

President



CONTENTS

	Page
IMPORTANT SAFETY INSTRUCTIONS	1
DESCRIPTION	11
1. Le Grand Palais 180	12
2. Le Château® 165	14
3. Le Château® 150	16
4. Le Château® 120	18
5. Le Château® 90	20
6. Le Château® 75	22
INSTALLATION	24
BEFORE DELIVERY	24
1. Safety requirements	24
2. Electrical supply	25
3. Gas supply	25
4. Installation	25
HANDLING INSTRUCTIONS	26
ASSEMBLY INSTRUCTIONS	28
1. Handrail installation	28
2. Riser installation	28
3. Height adjustment	28
4. Gas chimney protection installation	29
CONNECTIONS	29
1. Electrical connection	30
2. Gas connection	32
OPERATION	34
1. Tests	34
1.1. Electric oven	34
1.2. "Baking stone" (sold separately)	34
1.3. Electric broiler (gas or electric oven)	35
1.4. Gas oven with electronic ignition	35
1.5. Open tops, hot tops, open top broiler or griddle with ignition	35
1.6. Round electric plates	35
MAINTENANCE	36
IMPORTANT INFORMATION	36
1. Adjustment of the low flame settings	37
2. Fuel conversion	37
3. Gas Pressure Regulator	39
4. Replacing the oven light	40
ELECTRICAL DIAGRAMS	41
1. Gas cooktop electronic ignition	41
2. Electric Cooktop section	42
3. Gas Oven - electronic ignition	43
4. Electric Oven	44
WARRANTY	45

DESCRIPTION

The La Cornue “Château Centenaire” series consist of 6 models of stoves and hobs:

- Le Grand Palais 180, width 70 ⁷/₈” (1,800 mm).
- Le Château 165, width 65” (1,650 mm).
- Le Château 150, width 59” (1,500 mm).
- Le Château 120, width 47 ¹/₄” (1,200 mm).
- Le Château 90, width 35” (900 mm).
- Le Château 75, width 29 ¹/₂” (750 mm).

Refer to nameplate to determine type of gas for which appliance is equipped.

Gas input ratings for each kind of burner (BTU/hr):

Burners	Input ratings (BTU / hr)	
	Natural gas	Propane gas
Open top:		
- Maxi burner	22,000 (6.44 kW)	22,000 (6.44 kW)
- Large burner	17,000 (4.98 kW)	12,500 (3.66 kW)
- Small burner	7,500 (2.19 kW)	6,000 (1.75 kW)
Hot top	12,000 (3.51 kW)	11,500 (3.37 kW)
Open top broiler / Griddle	14,500 (4.24 kW)	14,500 (4.24 kW)
Small oven	22,000 (6.44 kW)	22,000 (6.44 kW)
Large oven	22,000 (6.44 kW)	22,000 (6.44 kW)

Electrical power supplied by each heating element (W):

Elements		Power
Top surface element		2,000 W each (4,000 W total)
Large oven	Backing	3,500 W
	Broiling	2,500 W
Small oven	Backing	1,750 W
	Broiling	1,750 W
Oven bulb (1 per oven)		25 W
Oven ignition		25 W
Hob ignition		25 W
Baking stone		3,000 W

I. DESCRIPTION "LE GRAND PALAIS 180"

The "Le Grand Palais 180" range, one of the models of the "La Cornue" series consists of:

- 2 thermostatically-controlled **large vaulted ovens**, gas and electric (only ranges).
- One cooktop bounded at the rear by a stainless steel backsplash creating a gap between the range and the wall, thus ensuring the removal of burnt gases and smells (ranges and cooktops).

For each gas type and for each model, the tables below summarize the total electric power (W) and the input ratings (BTU/hr).

MODEL	TOTAL POWER Watt	240 V a.c. Power supply		For supply connections use : N° AWG
		Intensity Amps	Wire section in mm2	
RANGES				
GPA--GEUN0	8,600	36	6	8
GPA--GEUN1	8,600	36	6	8
GPA--GEUN4	12,600	53	10	6
GPA--GEUN6	12,600	53	10	6
GPA--GEUNC	12,600	53	10	6
GPA--GEUNM	12,600	53	10	6
COOKTOPS				
TGP--00UN0	25	0.1	0.5	18
TGP--00UN1	25	0.1	0.5	18
TGP--00UN4	4,025	17	2.5	12
TGP--00UN6	4,025	17	2.5	12
TGP--00UNC	4,025	17	2.5	12
TGP--00UNM	4,025	17	2.5	12

MODEL	Cooktop equipment						Large oven		Total Gas input ratings (BTU / hr)	
	Open top			Hot top	Broiler	Round electric plates	Gas	Electric	Natural Gas	Propane
	Maxi burner	Large burner	Small burner							
RANGES										
GPA--GEUN0		2	2	2			1	1	95,000	82,000
GPA--GEUN1	1	2	2	1			1	1	105,000	92,500
GPA--GEUN4		2	2	1	1	2	1	1	97,500	85,000
GPA--GEUN6		2	2	1	1	2	1	1	97,500	85,000
GPA--GEUNC		1	1	2		2	1	1	70,500	63,500
GPA--GEUNM	1	1	1	1		2	1	1	80,500	74,000
COOKTOPS										
TGP--00UN0		2	2	2					73,000	60,000
TGP--00UN1	1	2	2	1					83,000	70,500
TGP--00UN4		2	2	1	1	2			75,500	63,000
TGP--00UN6		2	2	1	1	2			75,500	63,000
TGP--00UNC		1	1	2		2			48,500	41,500
TGP--00UNM	1	1	1	1		2			58,500	52,000

Dimensions

	Ranges	Cooktops
— Appliance height:	36" (914 mm)	7 7/8" (200 mm)
— Height with backsplash:	38" (964 mm)	9 7/8" (250 mm)
— Width:	70 7/8" (1,800 mm)	70 7/8" (1,800 mm)
— Weight:	280 to 320 kg, (617 to 705 lbs)	100 to 130 kg according to the models (220 to 286 lbs)
— Depth to the wall:		
- Front:	26 1/8" (665 mm)	
- Rail:	31" (785 mm)	
- Hob edge:	27 1/2" (700 mm)	
Thickness:	1 5/8" (40 mm)	

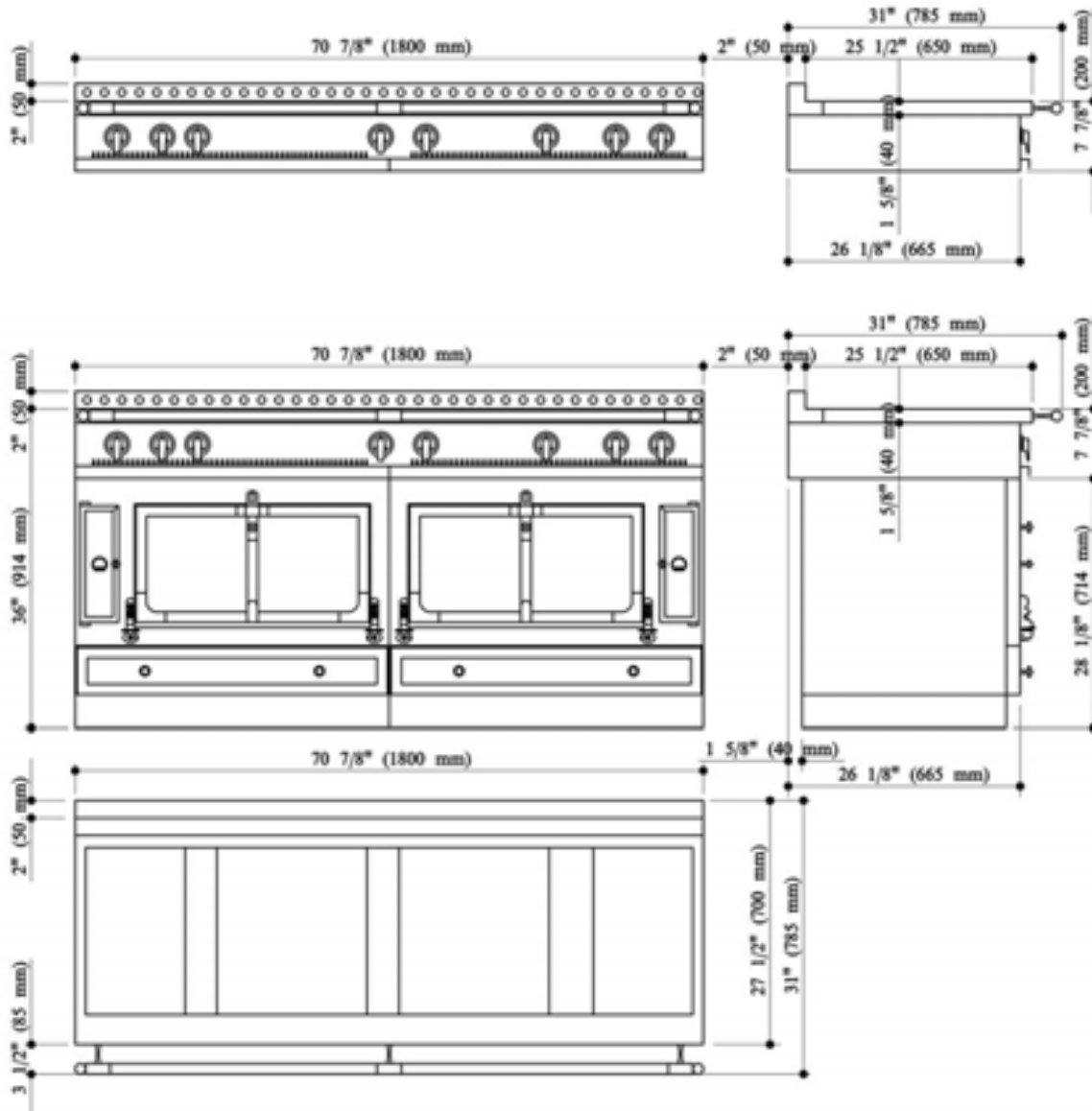

2. DESCRIPTION "LE CHATEAU® 165"

The "Le Château 165" range, one of the models of the "La Cornue" series consists of:

- 2 thermostatically-controlled **vaulted ovens**, 1 large gas oven and 1 small electric oven (only ranges).
- One cooktop bounded at the rear by a stainless steel backsplash creating a gap between the range and the wall, thus ensuring the removal of burnt gases and smells (ranges and cooktops).

For each gas type and for each model, the tables below summarize the total electric power (W) and the input ratings (BTU/hr).

MODEL	TOTAL POWER Watt	240 V a.c. Power supply		For supply connections use : N° AWG
		Intensity Amps	Wire section in mm2	
RANGES				
CHR--GEUL0	7,350	31	4	10
CHR--GEUL1	7,350	31	4	10
CHR--GEUL4	11,350	47	10	6
CHR--GEUL6	11,350	47	10	6
CHR--GEULC	11,350	47	10	6
CHR--GEULM	11,350	47	10	6
COOKTOPS				
THR--00UL0	25	0.1	0.5	18
THR--00UL1	25	0.1	0.5	18
THR--00UL4	4,025	17	2.5	12
THR--00UL6	4,025	17	2.5	12
THR--00ULC	4,025	17	2.5	12
THR--00ULM	4,025	17	2.5	12

MODEL	Cooktop equipment						Ovens		Total Gas input ratings (BTU / hr)	
	Open top			Hot top	Broiler	Round electric plates	Large oven Gas	Small oven Electric	Natural Gas	Propane
	Maxi burner	Large burner	Small burner							
RANGES										
CHR--GEUL0		2	2	2			1	1	95,000	82,000
CHR--GEUL1	1	2	2	1			1	1	105,000	92,500
CHR--GEUL4		2	2	1	1	2	1	1	97,500	85,000
CHR--GEUL6		2	2	1	1	2	1	1	97,500	85,000
CHR--GEULC		1	1	2		2	1	1	70,500	63,500
CHR--GEULM	1	1	1	1		2	1	1	80,500	74,000
COOKTOPS										
THR--00UL0		2	2	2					73,000	60,000
THR--00UL1	1	2	2	1					83,000	70,500
THR--00UL4		2	2	1	1	2			75,500	63,000
THR--00UL6		2	2	1	1	2			75,500	63,000
THR--00ULC		1	1	2		2			48,500	41,500
THR--00ULM	1	1	1	1		2			58,500	52,000

Dimensions

	Ranges	Cooktops
— Appliance height:	36" (914 mm)	7 7/8" (200 mm)
— Height with backsplash:	38" (964 mm)	9 7/8" (250 mm)
— Width:	65" (1,650 mm)	65" (1,650 mm)
— Weight:	260 to 290 kg, (573 to 639 lbs)	90 to 130 kg according to the models (198 to 286 lbs)
— Depth to the wall:		
- Front:	26 1/8" (665 mm)	
- Rail:	31" (785 mm)	
- Hob edge:	27 1/2" (700 mm)	
Thickness:	1 5/8" (40 mm)	

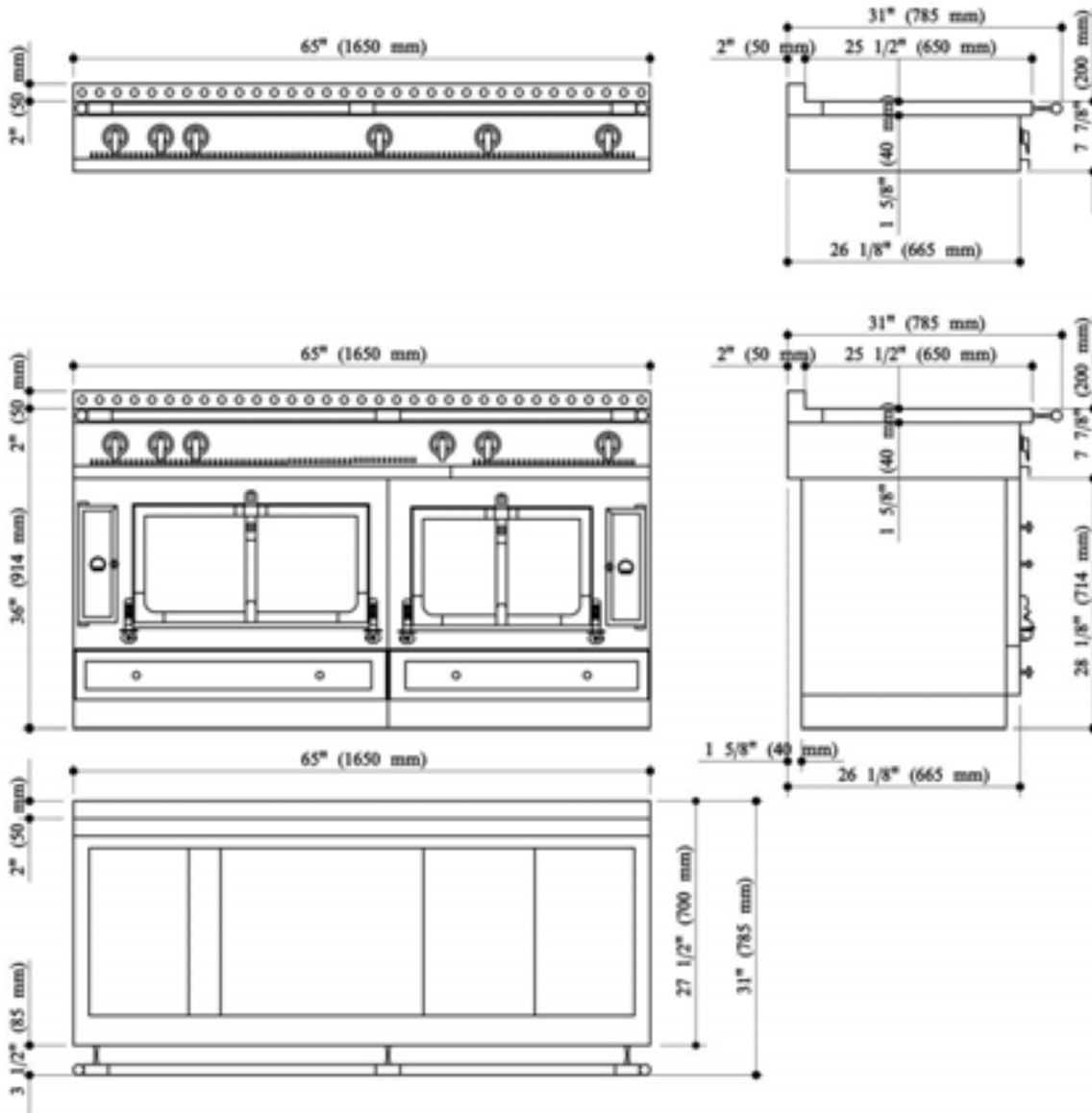

3. DESCRIPTION "LE CHATEAU® 150"

The "Le Château 150" range, one of the models of the "La Cornue" series consists of:

- 2 thermostatically-controlled **small vaulted ovens**, gas and electric (only ranges).
- One cooktop bounded at the rear by a stainless steel backsplash creating a gap between the range and the wall, thus ensuring the removal of burnt gases and smells (ranges and cooktops).

For each gas type and for each model, the tables below summarize the total electric power (W) and the input ratings (BTU/hr).

MODEL	TOTAL POWER Watt	240 V a.c. Power supply		For supply connections use : N° AWG
		Intensity Amps	Wire section in mm ²	
RANGES				
CH5--GEUK0	6,600	28	4	10
CH5--GEUK1	6,600	28	4	10
CH5--GEUK3	10,600	44	10	6
CH5--GEUK5	6,600	28	4	10
CH5--GEUK6	6,600	28	4	10
CH5--GEUK8	6,600	28	4	10
CH5--GEUK9	6,600	28	4	10
CH5--GEUKC	10,600	44	10	6
CH5--GEUKD	10,600	44	10	6
CH5--GEUKM	10,600	44	10	6
CH5--GEUKZ	10,600	44	10	6
COOKTOPS				
TH5--00UK0	25	0.1	0.5	18
TH5--00UK1	25	0.1	0.5	18
TH5--00UK3	4,025	17	2.5	12
TH5--00UK5	25	0.1	0.5	18
TH5--00UK6	25	0.1	0.5	18
TH5--00UK8	25	0.1	0.5	18
TH5--00UK9	25	0.1	0.5	18
TH5--00UKC	4,025	17	2.5	12
TH5--00UKD	4,025	17	2.5	12
TH5--00UKM	4,025	17	2.5	12
TH5--00UKZ	4,025	17	2.5	12

MODEL	Cooktop equipment						Small oven		Total Gas input ratings (BTU / hr)	
	Open top			Hot top	Broiler	Round electric plates	Gas	Electric	Natural Gas	Propane
	Maxi burner	Large burner	Small burner							
RANGES										
CH5--GEUK0		2	2	2			1	1	95,000	82,000
CH5--GEUK1	1	2	2	1			1	1	105,000	92,500
CH5--GEUK3		2	2	1		2	1	1	83,000	70,500
CH5--GEUK5		2	2	1	1		1	1	97,500	85,000
CH5--GEUK6	1	1	1	1	1		1	1	95,000	88,500
CH5--GEUK8		2	2	1	1		1	1	97,500	85,000
CH5--GEUK9	1	1	1	1	1		1	1	95,000	88,500
CH5--GEUKC		1	1	2		2	1	1	70,500	63,500
CH5--GEUKD		1	1	1	1	2	1	1	73,000	66,500
CH5--GEUKM	1	1	1	1		2	1	1	80,500	74,000
CH5--GEUKZ		1	1	1	1	2	1	1	73,000	66,500
COOKTOPS										
TH5--00UK0		2	2	2					73,000	60,000
TH5--00UK1	1	2	2	1					83,000	70,500
TH5--00UK3		2	2	1		2			61,000	48,500
TH5--00UK5		2	2	1	1				75,500	63,000
TH5--00UK6	1	1	1	1	1				73,000	66,500
TH5--00UK8		2	2	1	1				75,500	63,000
TH5--00UK9	1	1	1	1	1				73,000	66,500
TH5--00UKC		1	1	2		2			48,500	41,500
TH5--00UKD		1	1	1	1	2			51,000	44,500
TH5--00UKM	1	1	1	1		2			58,500	52,000
TH5--00UKZ		1	1	1	1	2			51,000	44,500

Dimensions

	Ranges	Cooktops
— Appliance height:	36" (914 mm)	7 7/8" (200 mm)
— Height with backsplash:	38" (964 mm)	9 7/8" (250 mm)
— Width:	59" (1,500 mm)	59" (1,500 mm)
— Weight:	250 to 280 kg, (550 to 617 lbs)	80 to 100 kg according to the models (176 to 220 lbs)
— Depth to the wall:		
- Front:	26 1/8" (665 mm)	
- Rail:	31" (785 mm)	
- Hob edge:	27 1/2" (700 mm)	
Thickness:	1 5/8" (40 mm)	

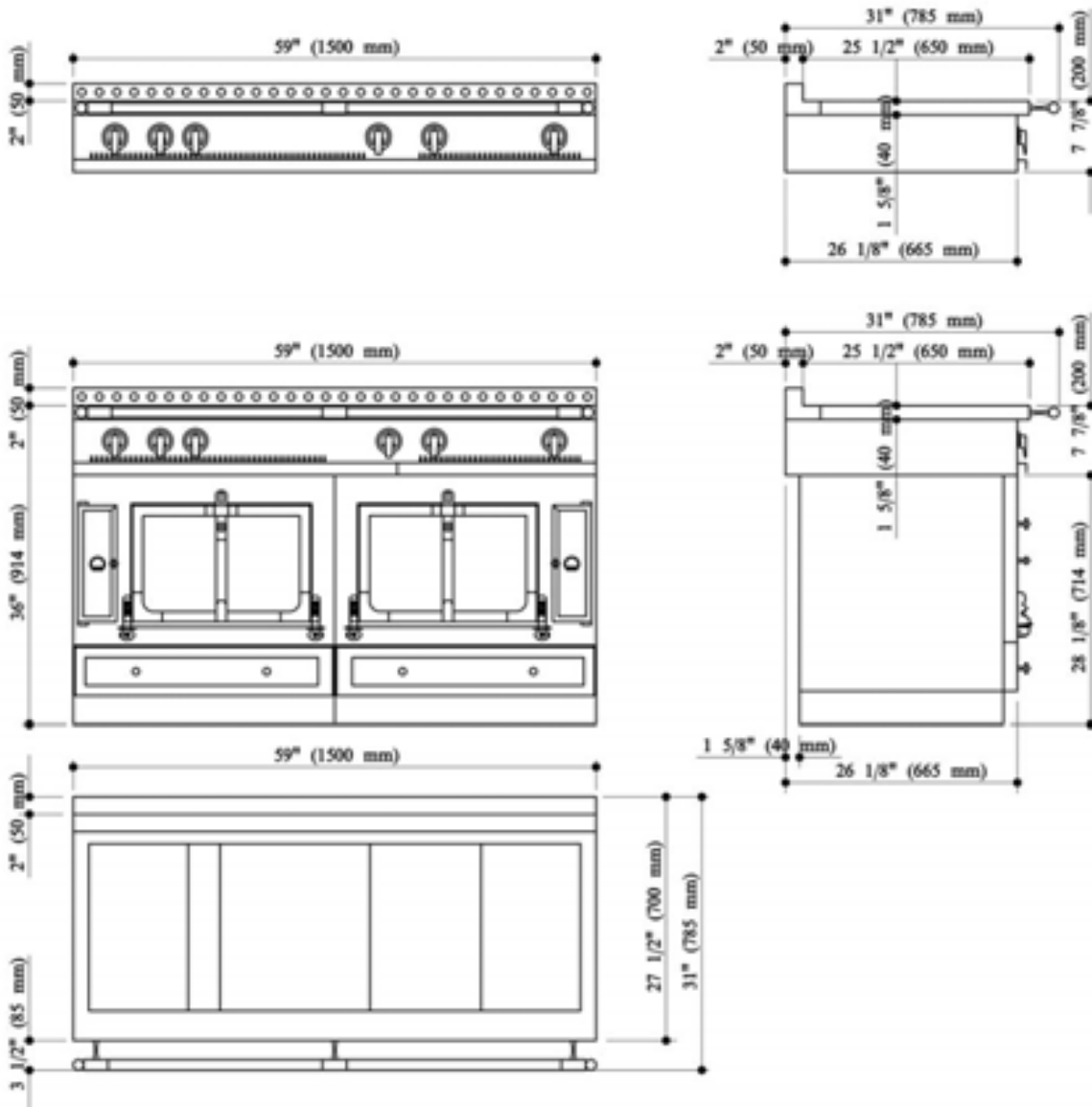

4. DESCRIPTION "LE CHATEAU® 120"

The "Le Château 120" range, one of the models of the "La Cornue" series consists of:

- 2 thermostatically-controlled **small vaulted ovens**, gas and electric (only ranges).
- One cooktop bounded at the rear by a stainless steel backsplash creating a gap between the range and the wall, thus ensuring the removal of burnt gases and smells (ranges and cooktops).

For each gas type and for each model, the tables below summarize the total electric power (W) and the input ratings (BTU/hr).

MODEL	TOTAL POWER Watt	240 V a.c. Power supply		For supply connections use : N° AWG
		Intensity Amps	Wire section in mm2	
RANGES				
CH2--GEUE0	6,600	28	4	10
CH2--GEUE1	6,600	28	4	10
CH2--GEUE2	6,600	28	4	10
CH2--GEUE3	6,600	28	4	10
CH2--GEUE4	10,600	44	10	6
CH2--GEUE6	6,600	28	4	10
CH2--GEUE7	6,600	28	4	10
CH2--GEUEC	10,600	44	10	6
CH2--GEUEZ	10,600	44	10	6
COOKTOPS				
TH2--00UE0	25	0.1	0.5	18
TH2--00UE1	25	0.1	0.5	18
TH2--00UE2	25	0.1	0.5	18
TH2--00UE3	25	0.1	0.5	18
TH2--00UE4	4,025	17	2.5	12
TH2--00UE6	25	0.1	0.5	18
TH2--00UE7	25	0.1	0.5	18
TH2--00UEC	4,025	17	2.5	12
TH2--00UEZ	4,025	17	2.5	12

MODEL	Cooktop equipment						Small oven		Total Gas input ratings (BTU / hr)	
	Open top			Hot top	Broiler	Round electric plates	Gas	Electric	Natural Gas	Propane
	Maxi burner	Large burner	Small burner							
RANGES										
CH2--GEUE0		2	2	1			1	1	83,000	70,500
CH2--GEUE1	1	2	2				1	1	93,000	81,000
CH2--GEUE2		1	1	1	1		1	1	73,000	66,500
CH2--GEUE3		1	1	1	1		1	1	73,000	66,500
CH2--GEUE4		1	1	1		2	1	1	58,500	52,000
CH2--GEUE6		2	2	1	1		1	1	97,500	85,000
CH2--GEUE7		2	2	1	1		1	1	97,500	85,000
CH2--GEUEC		1	1	1	1	2	1	1	73,000	66,500
CH2--GEUEZ		1	1	1	1	2	1	1	73,000	66,500
COOKTOPS										
TH2--00UE0		2	2	1					61,000	48,500
TH2--00UE1	1	2	2						71,000	59,000
TH2--00UE2		1	1	1	1				51,000	44,500
TH2--00UE3		1	1	1	1				51,000	44,500
TH2--00UE4		1	1	1		2			36,500	30,000
TH2--00UE6		2	2	1	1				75,500	63,000
TH2--00UE7		2	2	1	1				75,500	63,000
TH2--00UEC		1	1	1	1	2			51,000	44,500
TH2--00UEZ		1	1	1	1	2			51,000	44,500

Dimensions

	Ranges	Cooktops
— Appliance height:	36" (914 mm)	7 7/8" (200 mm)
— Height with backsplash:	38" (964 mm)	9 7/8" (250 mm)
— Width:	47 1/4" (1,200 mm)	47 1/4" (1,200 mm)
— Weight:	200 to 220 kg, (440 to 485 lbs)	80 to 100 kg according to the models (176 to 220 lbs)
— Depth to the wall:		
- Front:	26 1/8" (665 mm)	
- Rail:	31" (785 mm)	
- Hob edge:	27 1/2" (700 mm)	
Thickness:	1 5/8" (40 mm)	

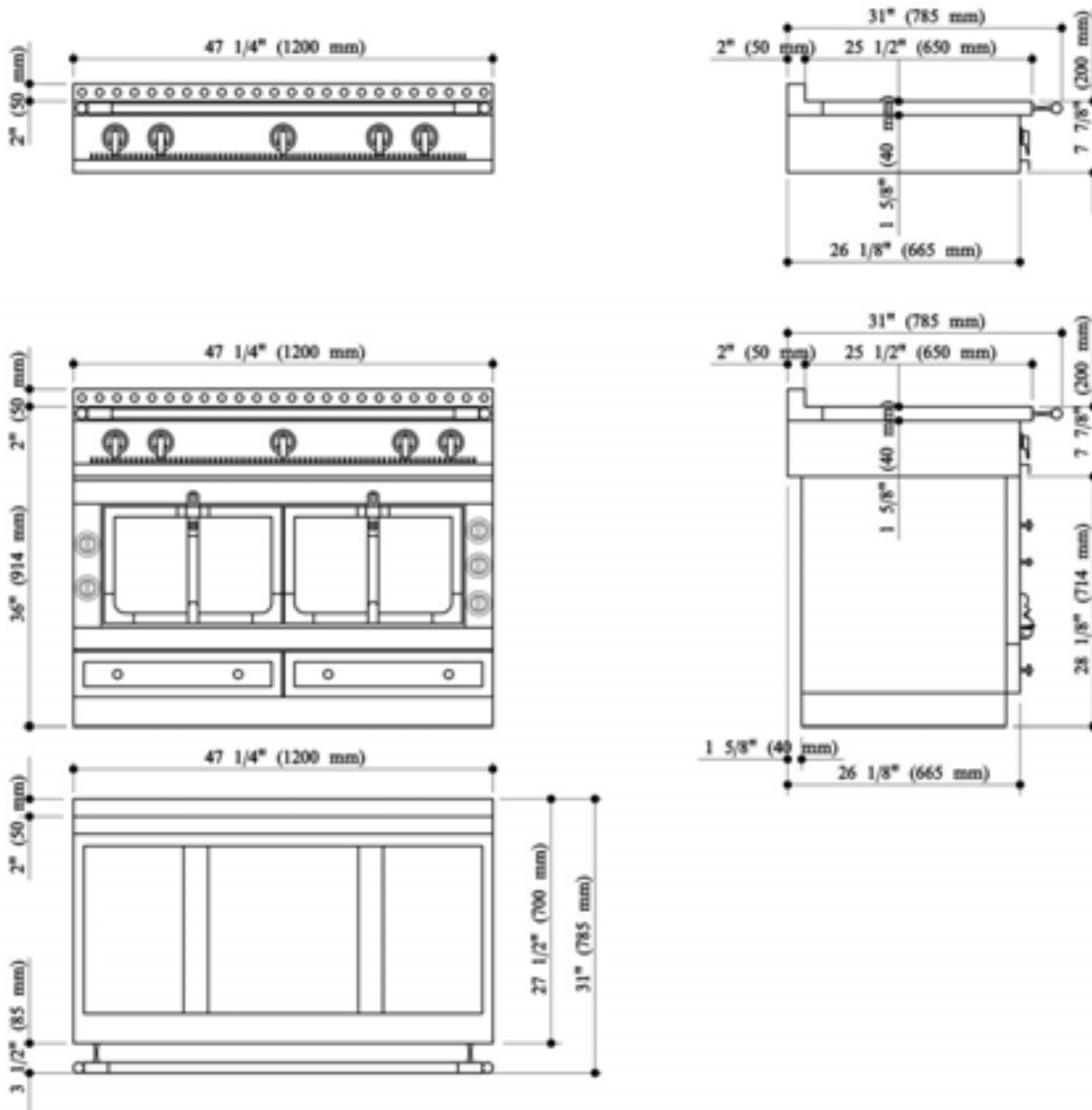

5. DESCRIPTION "LE CHATEAU® 90"

The "Le Château 90" range, one of the models of the "La Cornue" series consists of:

- 1 thermostatically-controlled **large vaulted oven**, gas or electric (only ranges).
- One cooktop bounded at the rear by a stainless steel backsplash creating a gap between the range and the wall, thus ensuring the removal of burnt gases and smells (ranges and cooktops).

For each gas type and for each model, the tables below summarize the total electric power (W) and the input ratings (BTU/hr).

MODEL	TOTAL POWER Watt	240 V a.c. Power supply		For supply connections use : N° AWG
		Intensity Amps	Wire section in mm2	
RANGES				
GC9--G0UC0	2,575	11	2	14
GC9--E0UC0	6,050	25	4	10
GC9--G0UC1	2,575	11	2	14
GC9--E0UC1	6,050	25	4	10
GC9--G0UC2	2,575	11	2	14
GC9--E0UC2	6,050	25	4	10
GC9--G0UC3	2,575	11	2	14
GC9--E0UC3	6,050	25	4	10
GC9--G0UC4	2,575	11	2	14
GC9--E0UC4	6,050	25	4	10
GC9--G0UC5	6,575	27	4	10
GC9--E0UC5	10,050	42	10	6
COOKTOPS				
TC9--00UC0	25	0.1	0.5	18
TC9--00UC1	25	0.1	0.5	18
TC9--00UC2	25	0.1	0.5	18
TC9--00UC3	25	0.1	0.5	18
TC9--00UC4	25	0.1	0.5	18
TC9--00UC5	4,025	17	2.5	12

MODEL	Cooktop equipment						Large oven		Total Gas input ratings (BTU / hr)	
	Open top			Hot top	Broiler	Round electric plates	Gas	Electric	Natural Gas	Propane
	Maxi burner	Large burner	Small burner							
RANGES										
GC9--G0UC0		1	1	1			1		58,500	52,000
GC9--E0UC0		1	1	1				1	36,500	30,000
GC9--G0UC1	1	1	1				1		68,500	62,500
GC9--E0UC1	1	1	1					1	46,500	40,500
GC9--G0UC2		2	2	1			1		83,000	70,500
GC9--E0UC2		2	2	1				1	61,000	48,500
GC9--G0UC3		1	1	1	1		1		73,000	66,500
GC9--E0UC3		1	1	1	1			1	51,000	44,500
GC9--G0UC4		1	1	1	1		1		73,000	66,500
GC9--E0UC4		1	1	1	1			1	51,000	44,500
GC9--G0UC5		1	1	1		2	1		58,500	52,000
GC9--E0UC5		1	1	1		2		1	36,500	30,000
COOKTOPS										
TC9--00UC0		1	1	1					36,500	30,000
TC9--00UC1	1	1	1						46,500	40,500
TC9--00UC2		2	2	1					61,000	48,500
TC9--00UC3		1	1	1	1				51,000	44,500
TC9--00UC4		1	1	1	1				51,000	44,500
TC9--00UC5		1	1	1		2			36,500	30,000

Dimensions

	Ranges	Cooktops
— Appliance height:	36" (914 mm)	7 7/8" (200 mm)
— Height with backsplash:	38" (964 mm)	9 7/8" (250 mm)
— Width:	35 1/2" (900 mm)	35 1/2" (900 mm)
— Weight:	100 to 150 kg, (220 to 330 lbs)	70 to 100 kg according to the models (154 to 220 lbs)
— Depth to the wall:		
- Front:	26 1/8" (665 mm)	
- Rail:	31" (785 mm)	
- Hob edge:	27 1/2" (700 mm)	
Thickness:	1 5/8" (40 mm)	

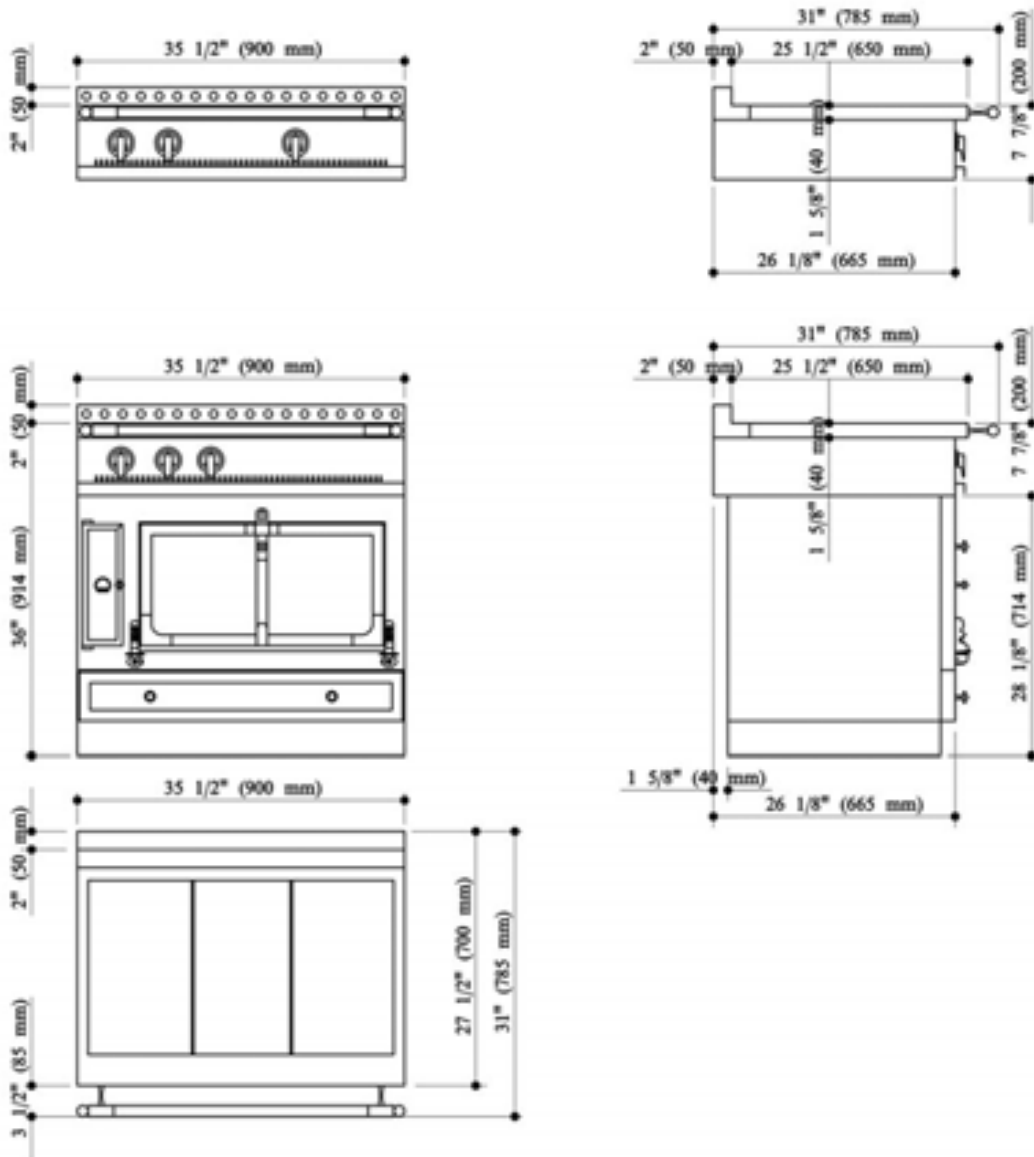

6. DESCRIPTION "LE CHATEAU® 75"

The "Le Château 75" range, one of the models of the "La Cornue" series consists of:

- 1 thermostatically-controlled **small vaulted oven**, gas or electric (only ranges).
- One cooktop bounded at the rear by a stainless steel backsplash creating a gap between the range and the wall, thus ensuring the removal of burnt gases and smells (ranges and cooktops).

For each gas type and for each model, the tables below summarize the total electric power (W) and the input ratings (BTU/hr).

MODEL	TOTAL POWER Watt	240 V a.c. Power supply		For supply connections use : N° AWG
		Intensity Amps	Wire section in mm2	
RANGES				
CA7--G0UB0	1,825	8	2	14
CA7--E0UB0	4,800	20	2.5	12
CA7--G0UB1	1,825	8	2	14
CA7--E0UB1	4,800	20	2.5	12
CA7--G0UB2	1,825	8	2	14
CA7--E0UB2	4,800	20	2.5	12
CA7--E0UBA	12,775	53	10	6
COOKTOPS				
TA7--00UB0	25	0.1	0.5	18
TA7--00UB1	25	0.1	0.5	18
TA7--00UB2	25	0.1	0.5	18
TA7--00UBA	8,000	33	6	8

MODEL	Cooktop equipment						Small oven		Total Gas input ratings (BTU / hr)	
	Open top			Hot top	Broiler	Round electric plates	Gas	Electric	Natural Gas	Propane
	Maxi burner	Large burner	Small burner							
RANGES										
CA7--G0UB0		1	1	1			1		58,500	52,000
CA7--E0UB0		1	1	1				1	36,500	30,000
CA7--G0UB1	1	1	1				1		68,500	62,500
CA7--E0UB1	1	1	1					1	46,500	40,500
CA7--G0UB2		2	2				1		71,000	59,000
CA7--E0UB2		2	2					1	49,000	37,000
COOKTOPS										
TA7--00UB0		1	1	1					36,500	30,000
TA7--00UB1	1	1	1						46,500	40,500
TA7--00UB2		2	2						49,000	37,000

Dimensions

	Ranges	Cooktops
— Appliance height:	36" (914 mm)	7 7/8" (200 mm)
— Height with backsplash:	38" (964 mm)	9 7/8" (250 mm)
— Width:	29 1/2" (750 mm)	29 1/2" (750 mm)
— Weight:	100 to 130 kg, (220 to 286 lbs)	60 to 80 kg according to the models (130 to 176 lbs)
— Depth to the wall:		
- Front:	26 1/8" (665 mm)	
- Rail:	31" (785 mm)	
- Hob edge:	27 1/2" (700 mm)	
Thickness:	1 5/8" (40 mm)	

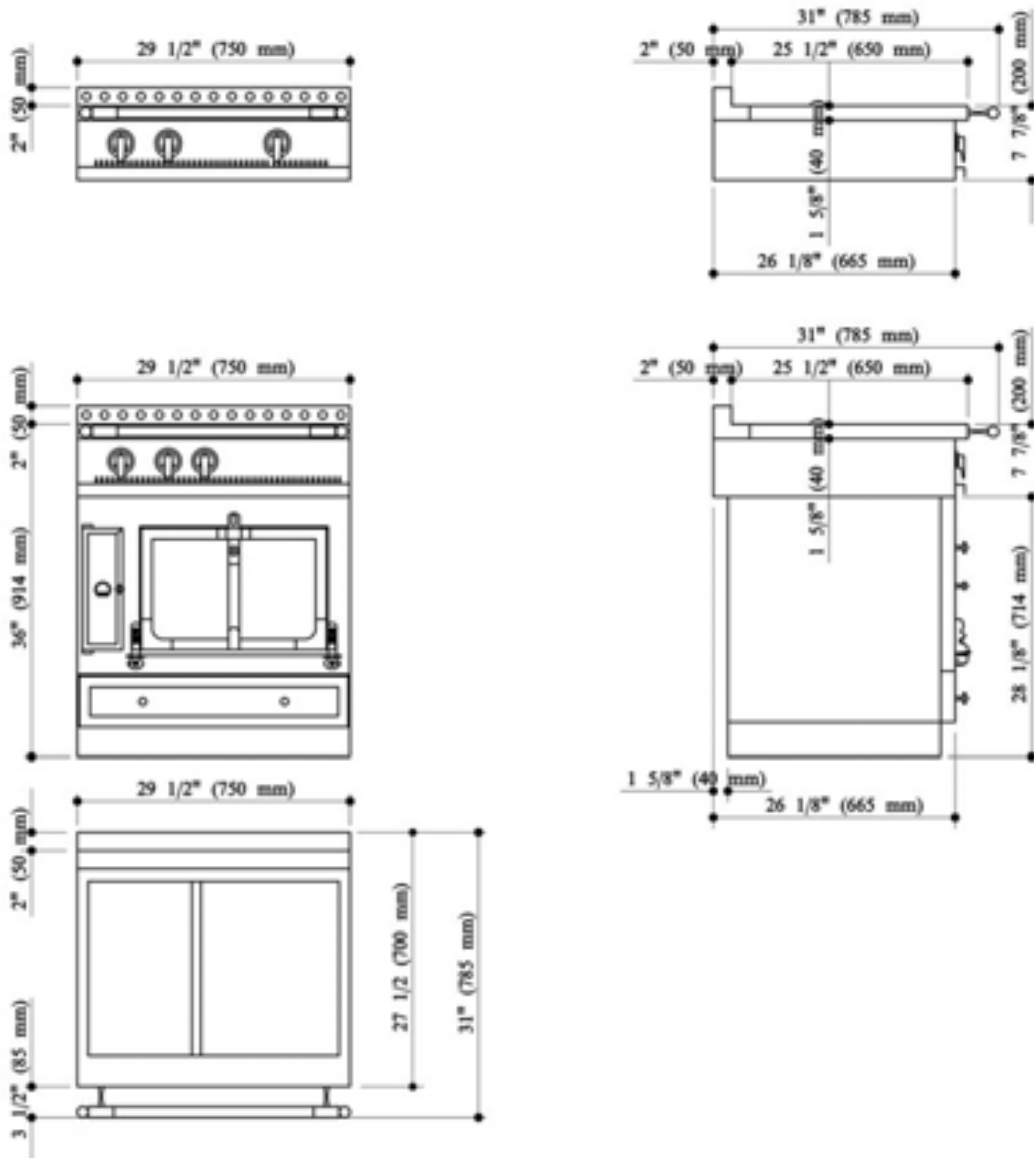

INSTALLATION

BEFORE DELIVERY

In order to be able to install your range or cooktop as soon as it is delivered, you must ensure that in your kitchen, the gas and electrical supplies are ready for it.

I. SAFETY REQUIREMENTS

1.1. Ventilation

The use of a gas cooking appliance results in the production of heat and moisture in the room in which it is installed. It is essential that the kitchen where the "La Cornue" stove will be installed has excellent ventilation **to the outside**, for vapor and combustion gases, **and a fresh air inlet**.

Do not use air recycling systems.

Ventilation exhaust devices can be **vapor aspirators** or **hoods**.

1.2. Clearances to combustible construction

The minimum horizontal distance from sides of appliance to the adjacent vertical combustible walls extending 18" above the top panel is 12".

The maximum depth of overhead cabinets is 13".

The minimum horizontal distances between overhead cabinets is not less than the nominal width of the appliance (A).

Any element, either an extraction hood or cabinet, situated directly above the range must be made of non-combustible material and placed at no less than 30" above range.

The recommended height is 36" above range.

May be installed with zero clearance between adjacent combustible construction below the cooking surface and the back and sides of the appliance.

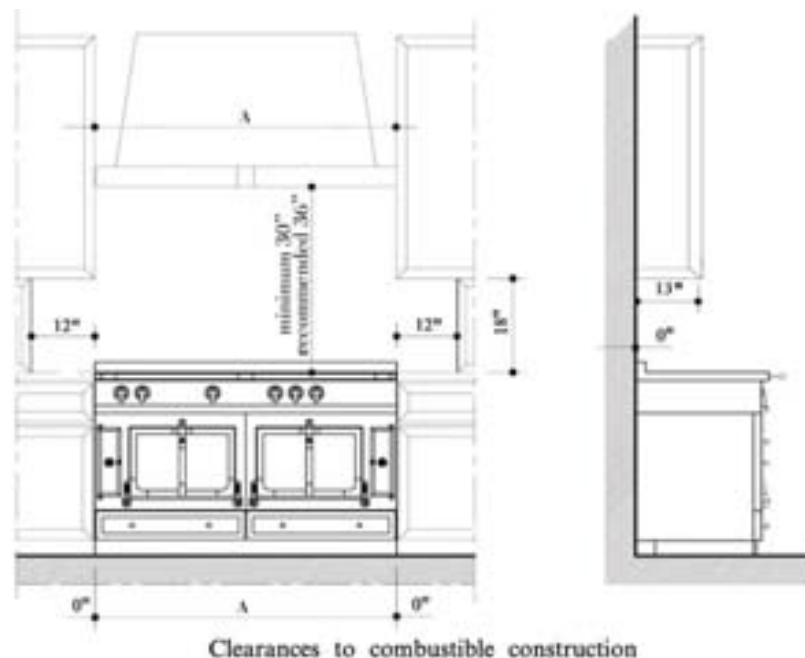

To be used in conjunction with a suitable ventilation hood.

2. ELECTRICAL SUPPLY

Voltage : 240 V a.c., single-phase, 3 wire system

Safety: The range, when installed must be electrically grounded in accordance with local codes, or in the absence of local codes, with the latest edition of the National Electrical Code, ANSI / NFPA 70 in the USA and the Canadian Electrical Code, CSA C22.2, in Canada as applicable.

Power: Check the power rating at your electric meter (maximal load) to ensure that it is suitable for your model, taking into account all other electrical appliances installed on the same circuit.

The tables in pages 11, 12, 14, 16, 18, 20 and 22 show the necessary power and amp ratings for each La Cornue model.

The power of the "La Cornue" stoves, **does not allow for a simple plug and socket connection**; the electrical connection must be made by means of an **adequate flexible cord**, built-in **junction box, with terminal blocks**; the box is located **12" from the floor**, on the wall behind the stove, on the right.

3. GAS SUPPLY

Use sealing compound on all pipe joints. Compound used must be resistant to the action of LP Gases.

The gas supply line to the appliance must be at least the same size as the gas inlet. An **easily accessible manual shutoff valve** must be installed, keeping in mind the fact that on the appliance, the gas inlet is located:

- On the left-hand side of the appliance, approximately 2 1/2" from the edge.
- **24" above the floor** (for the ranges).

NOTE :

Make sure that the supply line is clear of burrs and metal particles in order to avoid damage to the gas controls once the gas is turned on. The pipe connections can then be made

When your "La Cornue" appliance is installed between kitchen cabinets, the manual shutoff valve should be accessible. We recommend it be located at the rear of an adjacent cabinet.

According to gas regulations, any opening in the wall or on the floor for gas supply of the appliance must be properly sealed as well as any circulation of air between the gas supply room and the kitchen.

When all the work has been carried out on your gas supply network, ensure that no metallic burr can enter the supply tube of the stove and block the burners. Then make sure that all gas connections are properly sealed. Refer to page 34 for initial test of the unit prior to turning the gas on. Refer to "Important Safety Information" section, on pages 1 - 8.

4. INSTALLATION

In order to ensure that the range is perfectly horizontal, especially in a kitchen with old paving or flooring, we recommend that you install the stove on a wooden or cement base, the height of which will bring the hot top to a level in accordance with its environment or your requirements. We recommend a base of the exact size of the stove base.

Anti-Tip Device (only Château 90 & Château 75 models)

WARNING

Ranges Château 90 and Château 75 must be secured by Anti-Tip bracket supplied. See instructions to install (supplied with bracket). Unless properly installed, the range could be tipped by leaning on the door. Injury might result from spilled hot liquids or from the range itself.

HANDLING INSTRUCTIONS

The following instructions are to be followed by qualified personnel, trained to handle extremely heavy loads. Usually, a single-oven cooker can be lifted by two people, a double-oven cooker is best handled by at least four people.

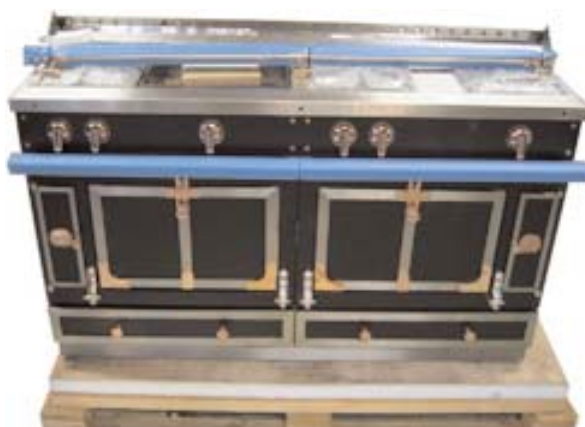

Complete cooker

1. In order to lighten the cooker, remove and set aside the drawers, the drip-trays, the backsplash, the handrail, the oven accessories, the pan supports, the solid top and any other accessories.
2. Remove oven doors by engaging the latches on the hinges and by pulling the door back and up.



3. Remove the plinthes/toe-kicks using a standard screwdriver.

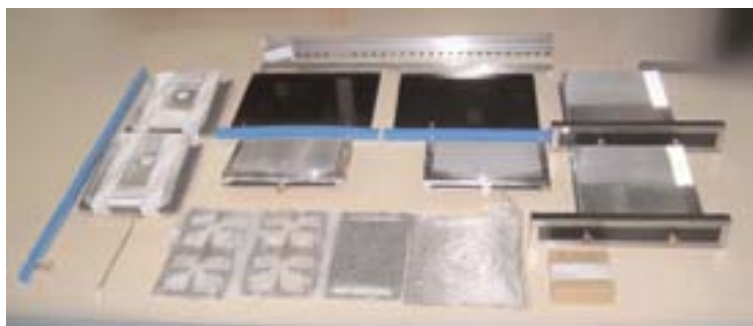

Full view of elements set aside.



Lighten cooker

4. Create a harness with four Installer's straps.
5. Twist the harness and tilt the cooker to place the harness.



6. When lifting up stairs, the straps of the handlers at the bottom should be shorter so the cooker stays level.
The back of the cooker should always face the inside side of the ramp.



ASSEMBLY INSTRUCTIONS

1. HANDRAIL INSTALLATION

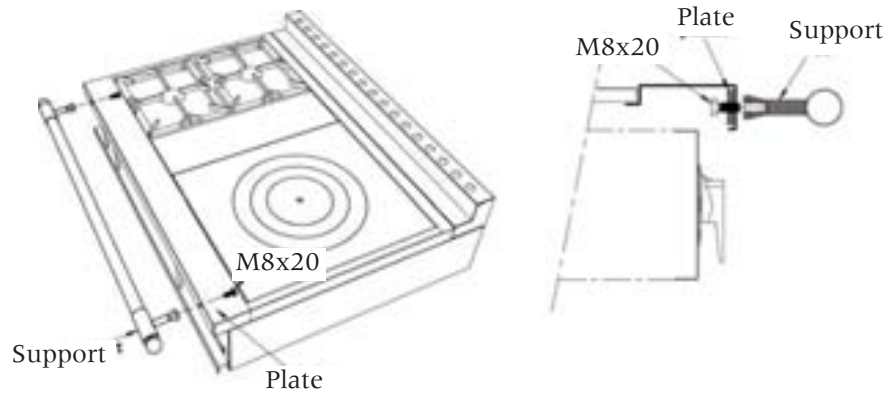

2. RISER / BACKSPLASH INSTALLATION

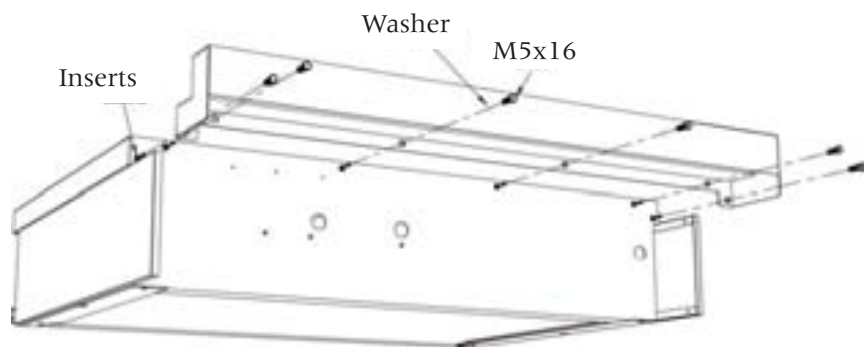
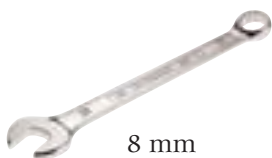

3. HEIGHT ADJUSTMENT

Château cookers are equipped with adjustable legs so the height of the cooktop can vary from 895 mm (35.24 in) to 915 mm (36.02 in). Remove the drawers and plinthes/toe-kicks, set the cooker in place, screw up the central legs so the cooker rests on the outside legs and adjust the height. Once the cooker is resting at the right height and is level, screw down the central legs to balance the weight.

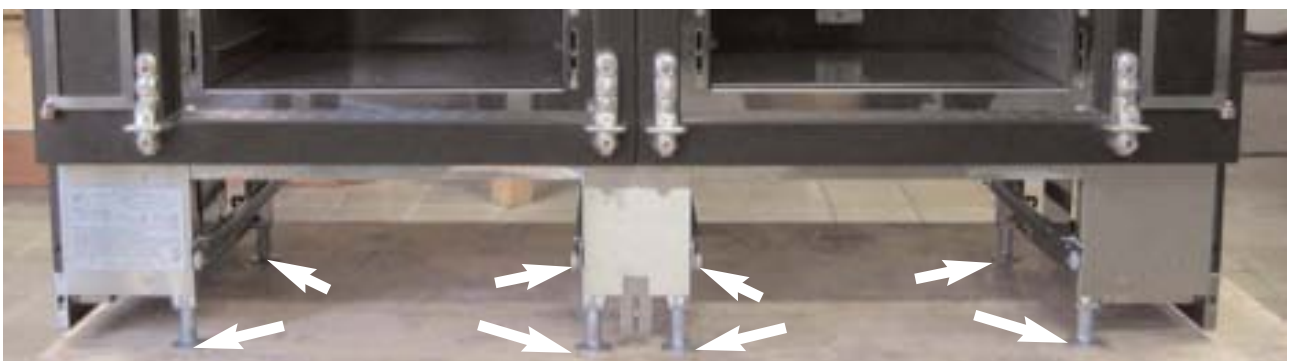

4. GAS CHIMNEY PROTECTION INSTALLATION

Gas chimney protection plate comes separately in the package and needs to be installed above the flue channel behind the gas oven.



Gas oven chimney protection

2 x Screw M5 x 16 mm + washer

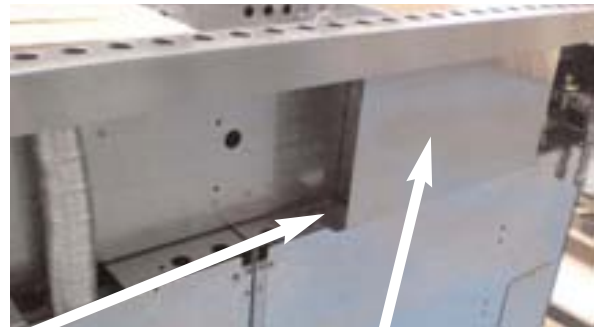

Gas oven chimney protection

CONNECTIONS

This appliance must be installed by a qualified La Cornue professional in accordance with the current regulations in the country where the appliance is installed.

Side view
All Ranges

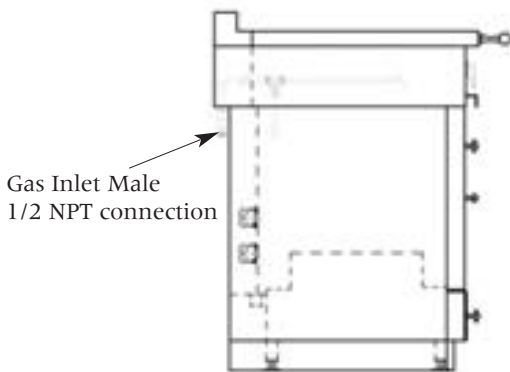

Rear view Ranges:
Château 90 and Château 75

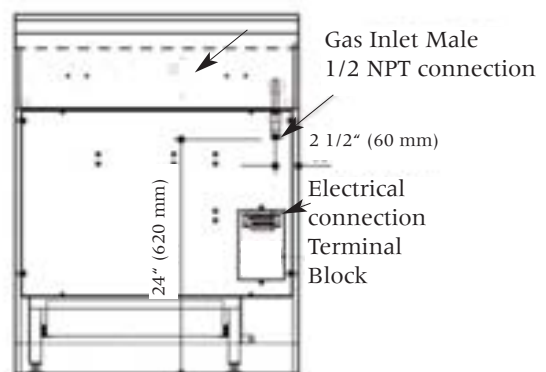

Rear view Ranges:
Grand Palais 180, Château 165, Château 150 and Château 120

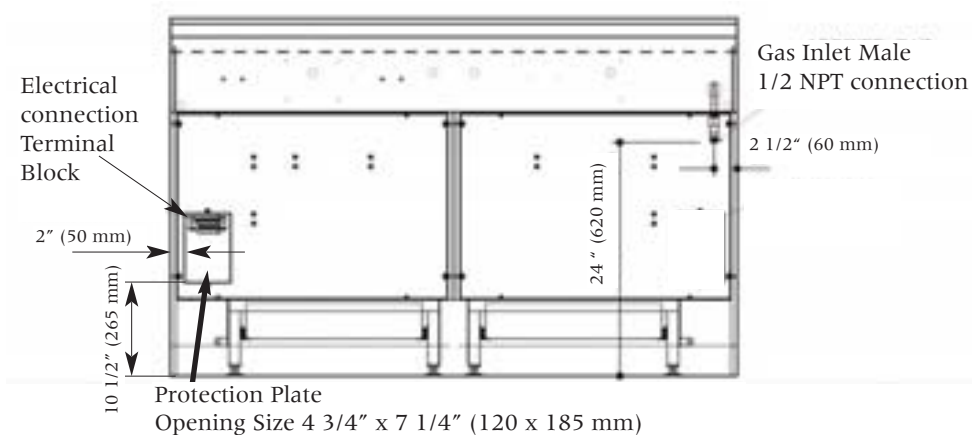

Rear view All Cooktops



I. ELECTRICAL CONNECTION

The appliance must be electrically installed and grounded in accordance with local codes or in the absence of such codes with the latest edition of the "National Electrical Code", ANSI/NFPA 70 in the USA, and CSA C22.2 "Canadian Electrical Code" - in Canada.

Disconnect all the power supply circuits before accessing the junction boxes.

This appliance must be supplied with 240 Volt and 60 Hz frequency, and connected to an individual, properly grounded branch circuit, protected by a circuit breaker or time-delay fuse, as noted on the rating plate.

Use only a 3-wire or a 4-wire UL-listed power-supply cord rated 120/240 Volts with a straight terminals.

Only a **4 wire cord** is to be used when the appliance is installed where grounding through the neutral conductor is prohibited, such as:

- new branch-circuit installations (1996 NEC),
- mobile homes,
- recreational vehicles or
- in an area where local codes prohibit grounding through the neutral.

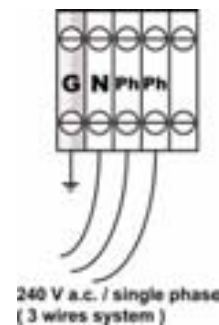

G-Ground N-Neutral Ph-Phase

The power of the electric elements for each appliance see page 11 and pages 12 - 22.

Wiring must conform to National Electric Codes.

If the electric service provided does not meet the above specifications, have a licensed electrician install an approved outlet.

Because range terminals are not accessible after range is in position, flexible service conduit or cord must be used. The range can then be easily disconnected for servicing etc.

The "La Cornue" appliance is supplied with a connection terminal block accessible by unscrewing the stainless steel protection plate on the backside.

1. Remove the screws and the protection plate on the backside of the ranges.

For the cooktops remove the cover of the main terminal box.



Ranges



Cooktops

2. Now the terminal block is accessible

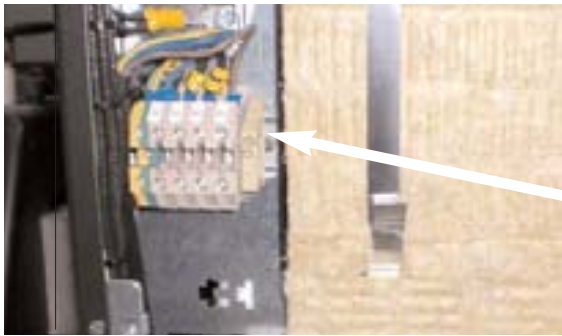

Ranges

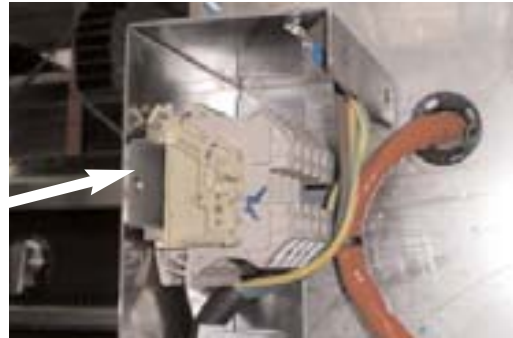

Cooktops

Terminal block

3. The appliance is shipped with a strain relief device to secure power cord. Insert the power cord through the strain relief and tighten it.



4. Insert the strain relief device into the hole and push it to the left. Tight up the power cord and strain relief device with the screw.



5. Install the power cord: attach the wires to the terminal block as follows:

- neutral (white wire) to N,
- the L1 and L2 (red and black wire) to P1 and P2,
- the ground to T (yellow / green).

NOTE: Make sure the wires are completely inserted into the terminals and secure connections are made.



6. Re-install the protection plate for the range or the cover for the cooktop.

7. Make sure that everything is properly secured.

REMINDER: connections to main power supply preferably suppose to be hardwired into the wall Junction Box compare using the Plugs and Outlet.

Fix the cable well below the hot air outlets, at the rear of the oven, never in front of them.

2. GAS CONNECTION

The installation of your La Cornue appliance must conform with local codes or, in the absence of local codes, in the USA with the "National Fuel Gas Code", ANSI Z223.1, latest edition, and, in Canada, with CAN/CGA - B149.1, and CAN CGA - B149.2, "Installation Code for Gas Burning Appliances".

All La Cornue ranges and cooktops are fully assembled and equipped for use with the type of gas shown on the rating plate of the appliance.

If no special instructions were mentioned upon ordering, the stove is fitted with orifices for natural gas.

Prior to installation, ensure that the local distribution conditions (nature of the gas and gas pressure) and the adjustment of the appliance are compatible.

The range is designed to operate at a manifold pressure of 5" of Water Column on natural gas, or a manifold pressure of 11" of Water Column on LP gas (Propane).

If the range is to be used on LP gas, a qualified LP installer must convert it. We recommend that the range be converted before installation.

For proper operation, the pressure of natural gas supplied to the regulator must be between 6" and 10" of water column.

For LP gas, the pressure supplied must be between 12" and 13" of water column.

When checking for proper operation of the regulator, the inlet pressure must be at least 1" greater than the operating (manifold) pressure as given above.

The pressure regulator located at the inlet of the range manifold must remain in the supply line regardless of whether natural or LP gas is being used.

A flexible metal appliance connector used to connect the range to the gas supply line should have an I.D. of 1/2" and be 5 feet in length for ease of installation.

The gas regulator on the appliance is set at the factory for pressures given by regulations.

For the La Cornue ranges and hobs the regulator and the pressure tap can be found on the hob's manifold located by the 2 left gas burners

Connect the Range to the Gas Supply

Shut off the main gas supply valve before disconnecting the old range and leave it off until the new hookup has been completed. Don't forget to relight the pilot on other gas appliances when you turn the gas back on.

Because hard piping restricts movement of the range, the use of a CSA International certified flexible metal appliance connector is recommended unless local codes require a hard piped connection.

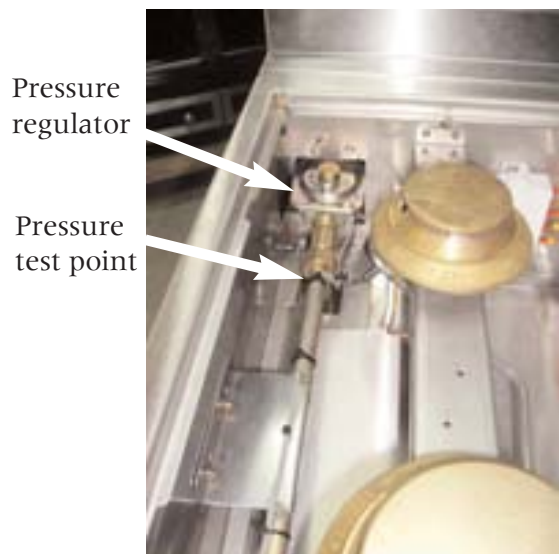

Never use an old connector when installing a new range. If the hard piping method is used, you must carefully align the pipe; the range cannot be moved after the connection is made. To prevent gas leaks, put pipe joint compound on, or wrap pipe thread tape with *Teflon** around, all male (external) pipe threads.

**Teflon*: Registered trademark of DuPont

Install a manual gas line shut-off valve in the gas line in an easily accessed location outside of the range. Make sure everyone operating the range knows where and how to shut off the gas supply to the range.

Connect flexible metal appliance connector to the adapter on the range. Position range to permit connection at the shut-off valve.

When all connections have been made, make sure all range controls are in the off position and turn on the main gas supply valve.

Use a liquid leak detector at all joints and connections to check for leaks in the system.

Use a product specifically manufactured for leak detection. Leak testing of the appliance shall be conducted in accordance to the manufacturer's instructions.

The appliance must be connected to the type of gas shown on the rating plate of the appliance.

The gas supply line must be at least a 1/2 inch pipe.

On all pipe joints use sealing compound that does not react to propane gas.

Check gas leaks by using a liquid leak detector.

Do not use an open flame

NOTE : Propane gas cylinders must never be located inside your home.

INSTALLER

Leave this manual with the appliance and advise the customer to keep it for future reference. Inform the consumer of the location of the gas shut-off valve.

OPERATION

The burners on the stoves of the "La Cornue" line are fitted with safety thermocouples: should a burner extinguish, the gas supply to this burner **is automatically cut off**.

I. TESTS

Upon initial test of unit

When first testing the gas operated burners, you may find they do not operate. **This is normal**, and is caused by air in the gas lines. Simply, operate each burner **starting with the top burners**, until all the air is displaced by the gas and ignition will result. This may take 1 to 5 minutes.

On first use, the electronic safety device of the gas oven may switch on (the red indicator light goes on).

Please press the reset button (B) until air is also displaced in the oven and the flame goes on.

1.1. Electric Oven

— Check "oven / baking stone" selector (E) is on the "oven" position (to the left).

— Set the oven thermostat (F) to the desired temperature setting. The green indicator light goes on.

After use, turn thermostat to "0".

1.2. Baking stone fonction (sold separatly):

The "baking stone" option includes: an oven-proof stone, a 3,000 Watt electric element and a stainless steel "bread server".

To turn on your "baking stone", follow these instructions:

- Remove the socket cover at the back of the oven meant to receive the "baking stone" electric element.
- Plug the heating element in its socket.
- Place the grill-tray on the second shelf-level, then place the stone on the grill.

- Preheat the oven by turning the selector (E) on the "oven" position (to the left) and the thermostat (F) to about 440°F. After 15 to 20 minutes preheating, turn the selector to the right on the "baking stone" position and begin to bake.

or

- Turn the selector (E) on the "baking stone" position (on the right) and turn the thermostat (F) to the desired temperature.
- After 10 to 15 minutes of pre-heating (depending on the desired temperature), you may begin to bake.

After use, turn thermostat to "0".

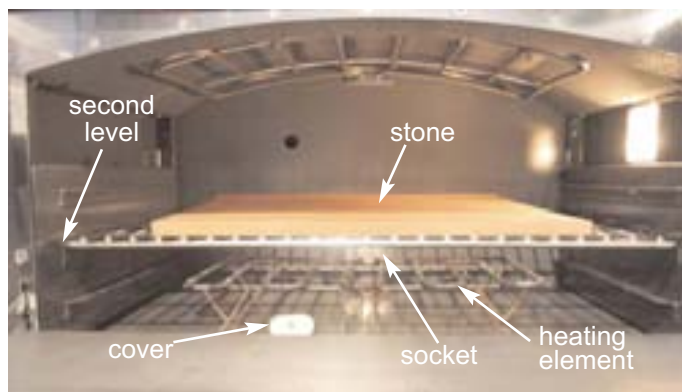
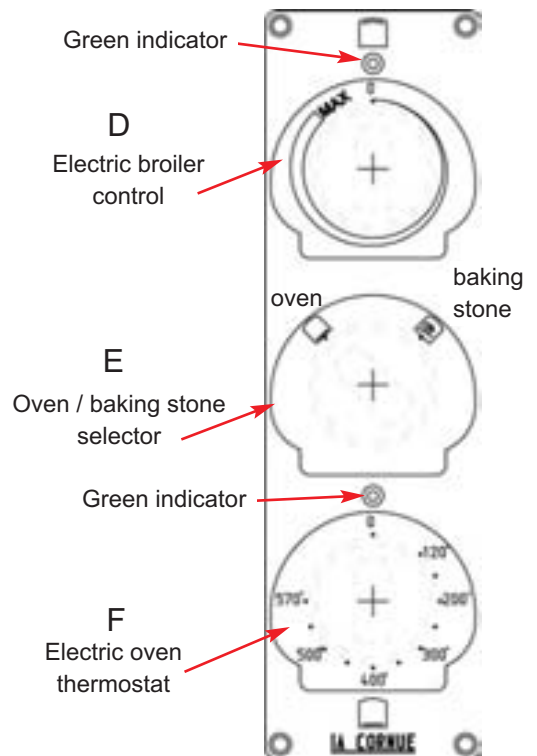

After cooking on the stone, let it cool down in the oven, then remove the stone and the heating element from the oven and place the cover back on the socket at the back of the oven.

! WARNING ! The baking stone and heating element are hot when functioning and after use. Do not touch before they have cooled.

1.3. Electric broiler (gas or electric oven)

- The level of the broiler is controlled by the upper knob (D). The green indicator light goes on.

After use, turn knob to "0".

1.4. Gas oven with electronic ignition

Turn the thermostat knob (A) to the desired temperature setting. The green indicator light goes on.

The electronic control provides a fully automatic thermostatic temperature control. During this process, it is normal that the flame will be totally shut on and off.

After use, turn thermostat to "0".

Note : The red light (C) at the bottom of the control panel indicates a problem in the ignition process. Whenever it goes on, please check that gas is flowing into the appliance, reset by pressing the "B" button.

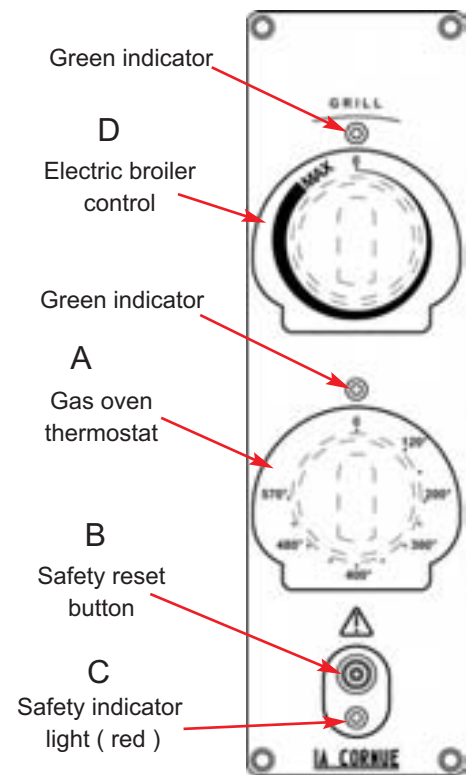

1.5. Open tops, hot tops, open top broiler or griddle with electronic ignition

To ignite the gas burner : press the control knob and rotate it counter clockwise, to the "big flame" position. The gas at the burner ignites automatically. Keep the knob pressed in for 5 to 10 seconds, or longer if necessary (up to 30 seconds on new equipment).

The sparking noise means that the ignition system is operating normally.

- **Low setting:** this is achieved by rotating the knob fully counter clockwise (small flame).

- **Shutoff:** bring the knob back to its vertical position by rotating it to the right.



1.6. Round electric plates

Depending on models, your cooking appliance may be equipped with an element with 2 round electric plates with a diameter of 18 cms for one and 20 cms for the other.

The round electric plates are made out of cast iron and are controlled by the knob located on the front of the cooktop.

Their total electrical output is 4,000 Watts (13,600 BTU's).

The knob have 3 marked positions ranging from warm (number 1) to very hot (number 3).

The largest of the two plates is the most powerful and is the one we suggest using when cooking with large pans.

MAINTENANCE

IMPORTANT INFORMATION

- ◆ Keep appliance area clear and free from combustible materials, gasoline and other flammable vapors and liquids.
- ◆ Do not obstruct the flow of combustion and ventilation air
- ◆ Contact the factory representative to perform maintenance and repairs.
- ◆ Clean appliance regularly, including special oven surfaces, with recommended cleaning agents.
- ◆ **Disconnect power supply to the range before servicing.**

IMPORTANT

This equipment is design-certified by a Nationally Recognized Testing Laboratory to the appropriate National Standards as indicated on the Equipment Rating Plate.

Any modification without written permission of the La Cornue Company voids the certification and warranty of this equipment.

Your selection of LA CORNUE equipment is your assurance of quality and dependability that reflects over 100 years of experience in manufacturing the finest gas cooking equipment.

You can always rely on your dealer and the Company to stand behind every product anywhere in the U.S.A. For additional equipment, service and information contact your dealer.

After-sales Service:



of 7:00 a.m. and 4:00 p.m. Pacific Time,
Monday through Friday, excluding national Holidays
by calling 877-LACORNUE

This section applies only for authorized service personnel recommended by your dealer

1. ADJUSTMENTS OF THE TOP BURNER LOW FLAME SETTINGS

Open top, hot top, open top broiler or griddle

Only the low settings for the burners of the open tops, hot top, open top broiler or griddle can be adjusted by means of the following procedure:

1. Turn gasburner on and set to lowest setting (small flame).
2. Remove the control knobs (A) and knob bezel by unscrewing the allen screw to access the by-pass screw.
3. Rotate the by-pass screw on the valve body **to the left to increase** the flow rate, **to the right to reduce it**.

Only for natural gas reduced flow rate can be adjusted. For the propane gas tighten the screw down.

Make sure that the resulting flame, at the lowest setting, is sufficiently strong to heat the thermocouple.

4. Place back control knob bezel and control knob and proceed with testing.

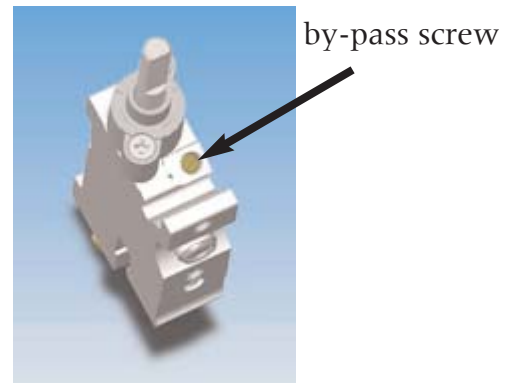
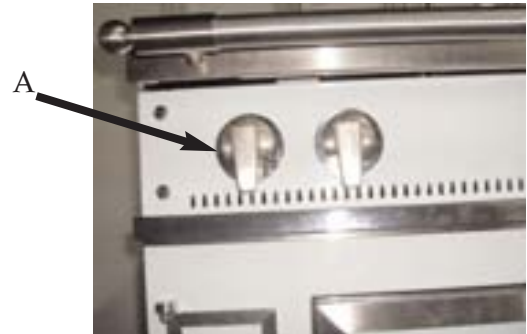

Caution: Make sure that there is a sufficient gap between the knobs and the front panel, since it is necessary to fully depress the knob before rotating it when igniting the burners.

2. FUEL CONVERSION

The orifices size depends on the type of gas. The table below is provided for you to determine which orifice should be used if the type of gas is changed.

		Open top			HOT TOP	Open top broiler or griddle	Small Oven	Big Oven
		Maxi burner	Large burner	Small burner				
Input rating (BTU/hr)	Natural gas 5" W.C.	22,000	17,000	7,500	12,000	14,500	22,000	22,000
	Propane gas 11" W.C.	22,000	12,500	6,000	11,500	14,500	22,000	22,000
Orifice sizes (Marking)	Natural gas 5" W.C.	216C	197C	124C	161C	170	215	215
	Propane gas 11" W.C.	140C	104C	76C	111C	120	150	150
Reduced flow rate by-pass	Natural gas 5" W.C.	62	55	33	55	62	----	----
	Propane gas 11" W.C.	Adjusted	Adjusted	Adjusted	Adjusted	Adjusted	----	----

The location of the orifices for the various gas burners differ (see photographs below).

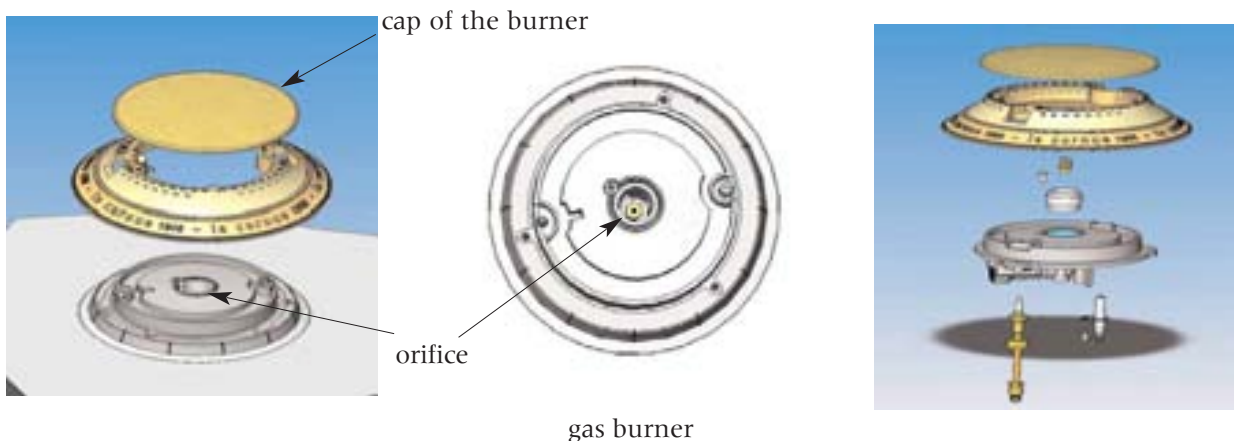

Note: Gas pressure regulator setting must also be adjusted when changing fuel type.

Orifices of gas burner and hotplate are replaced by means of this sequence:

1. Remove the brisk heat grill, then the pan.
2. Remove the cap of the burner.
3. Unscrew the orifice from the top using a standard 7 mm box spanner. Install the new orifice and screw it down completely.
4. Place the cap of the burner taking care to place it correctly on the body of the burner.
5. Place the pan, then the grill or the fire plate.

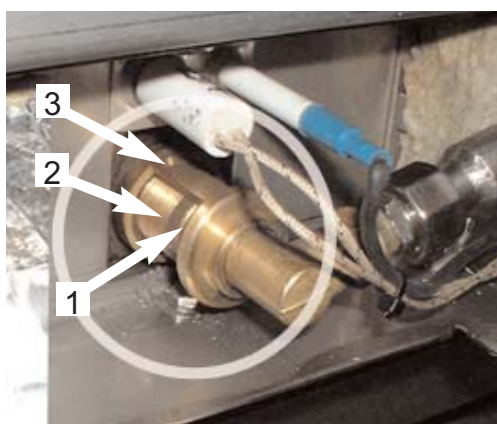

gas oven

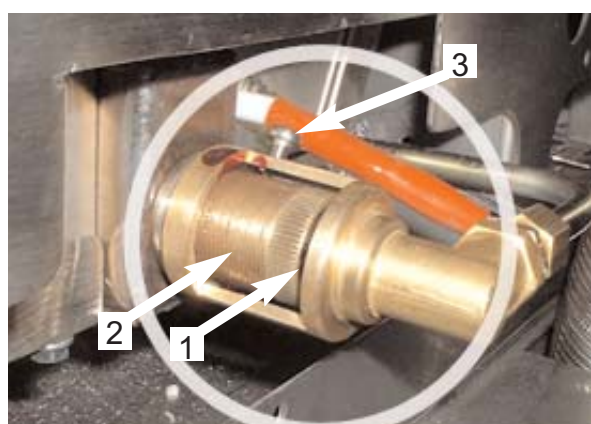

open top broiler or griddle

The orifices for gas oven, open top broiler or griddle are always replaced in the following sequence:

1. Screw the adjusting cone (2) and insert it into the mixing tube in order to free sufficient space for unscrewing the orifice.
2. Unscrew the orifice (1) with a 7 mm flat wrench.
3. Install the orifice (1) corresponding to the new type of gas and tighten it.
4. Ignite the burner and adjust the air inlet by screwing or unscrewing the adjusting cone (2) until you obtain a slightly blue flame showing no separation; separation of the flame is an indication that there is too much air.
5. Then block the adjusting cone (2) with the blocking washer (3).

Once you have changed the injectors, it is a good idea to adjust the low settings for the hob burners (see Section 1).

Save the orifices removed from the appliance for future use.



WARNING

The conversion kit shall be installed by a qualified service agency in accordance with the manufacturer's instructions and all applicable codes and requirements of the authority having jurisdiction. If the information in these instructions is not followed exactly, a fire, explosion or production of carbon monoxide may result causing property damage, personal injury or loss of life. The qualified service agency is responsible for the proper installation of this kit. The installation is not proper and complete until the operation of the converted appliance is checked as specified in the manufacturer's instructions supplied with the kit.

3. GAS PRESSURE REGULATOR

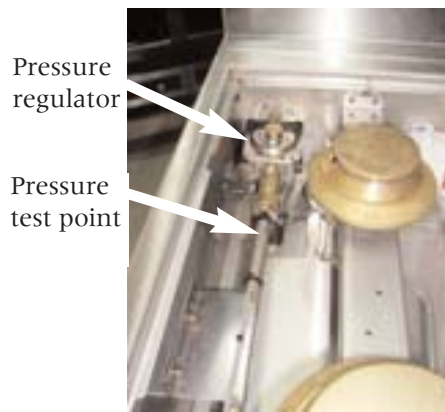
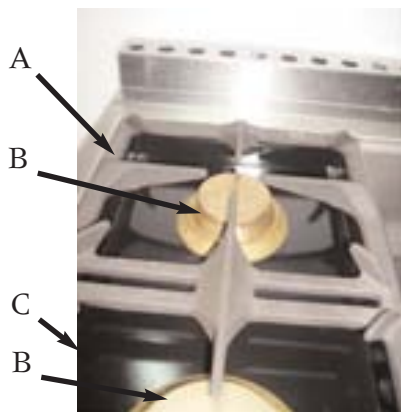

Pressure regulator

Remove the brisk heat grill (A), the cap of the burner (B), then the pan (C). The regulator is now accessible.

The regulator has a bayonet mounted top cap. Using a small coin press in and turn the cap to remove it. Turn the cap over so that the letters "LP" (for propan gas) or "NAT" (for natural gas) are visible on base of the hollow in the cap. Replace the cap making sure that the bayonet pins are securely located

Stick on label

Stick the appropriate label on to the data badge to indicate the gas the appliance is now set for.

Pressure Testing

Connect the appliance to the gas supply. Check the appliance is gas sound.

The gas pressure can be measured at the pressure test point on the appliance side on the manifold, near the pressure regulator.

4. REPLACING THE OVEN LIGHT

The light is located on the side at the top of the oven; it is automatically switched on when the oven door is opened. Please note: disconnect your oven before interfering with the light to prevent any risk of an electrical shock and to allow the appliance to cool down (if necessary).

Remove the protection glass and then unscrew the damaged light.
Refit a new light and the protection glass.



Technical characteristics of the light:

- 25W
- 230V - 240V
- 300°C
- E14 base

ELECTRICAL DIAGRAMS

USA & CANADA

I. GAS COOKTOP ELECTRONIC IGNITION.

“CAUTION - Label all wires prior to disconnection when servicing controls. Wiring errors can cause improper and dangerous operation.”
 “Verify proper operation after servicing.”

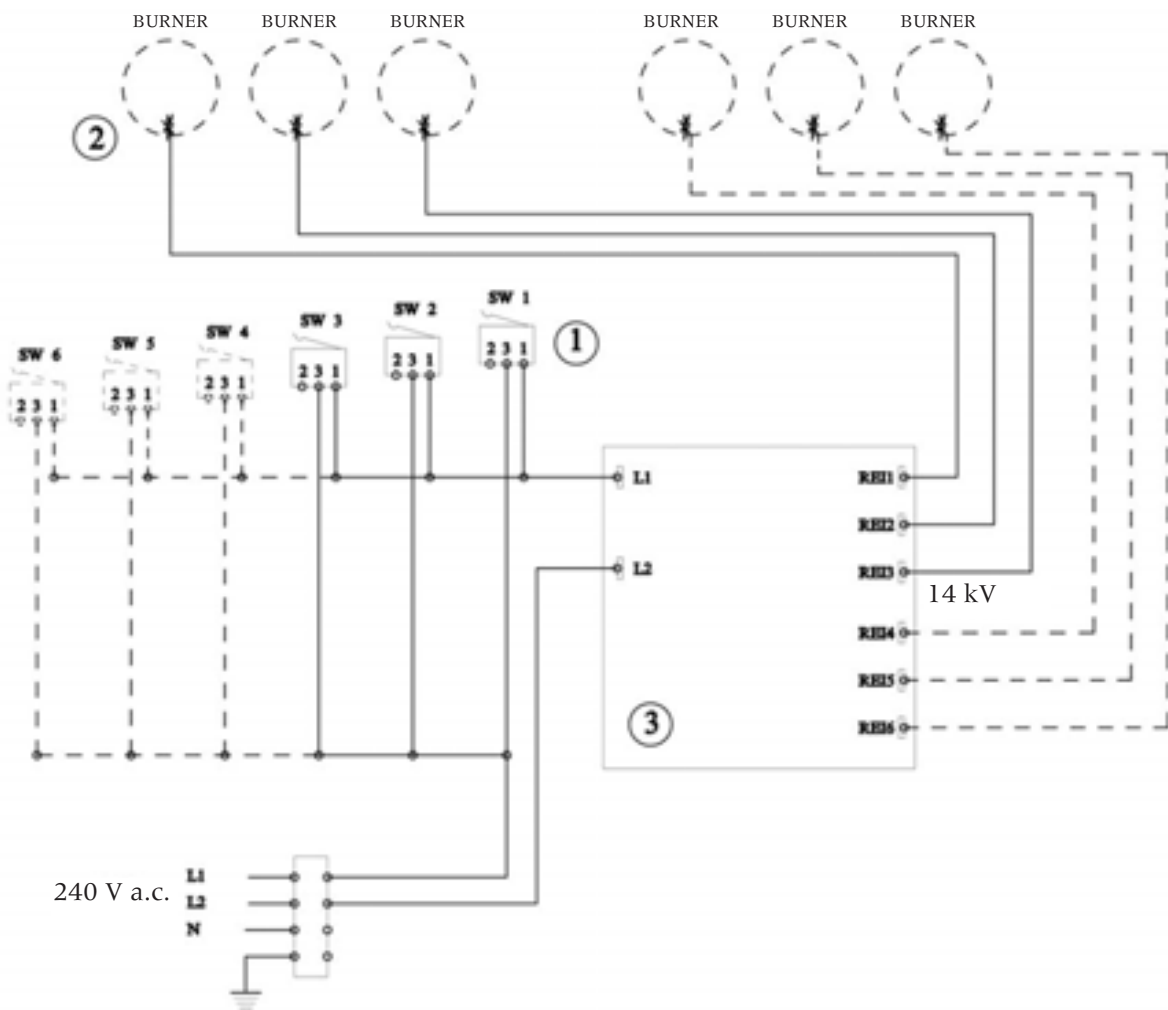

N°	Qty	Designation
1	3 - 6 *	Microswitch
2	3 - 6 *	Spark ignition electrode topvalve
3	1	Spark ignition module

* Depends on the number of burners

2. ELECTRIC COOKTOP SECTION (WHEN PROVIDED)

“CAUTION - Label all wires prior to disconnection when servicing controls. Wiring errors can cause improper and dangerous operation.”
 “Verify proper operation after servicing.”

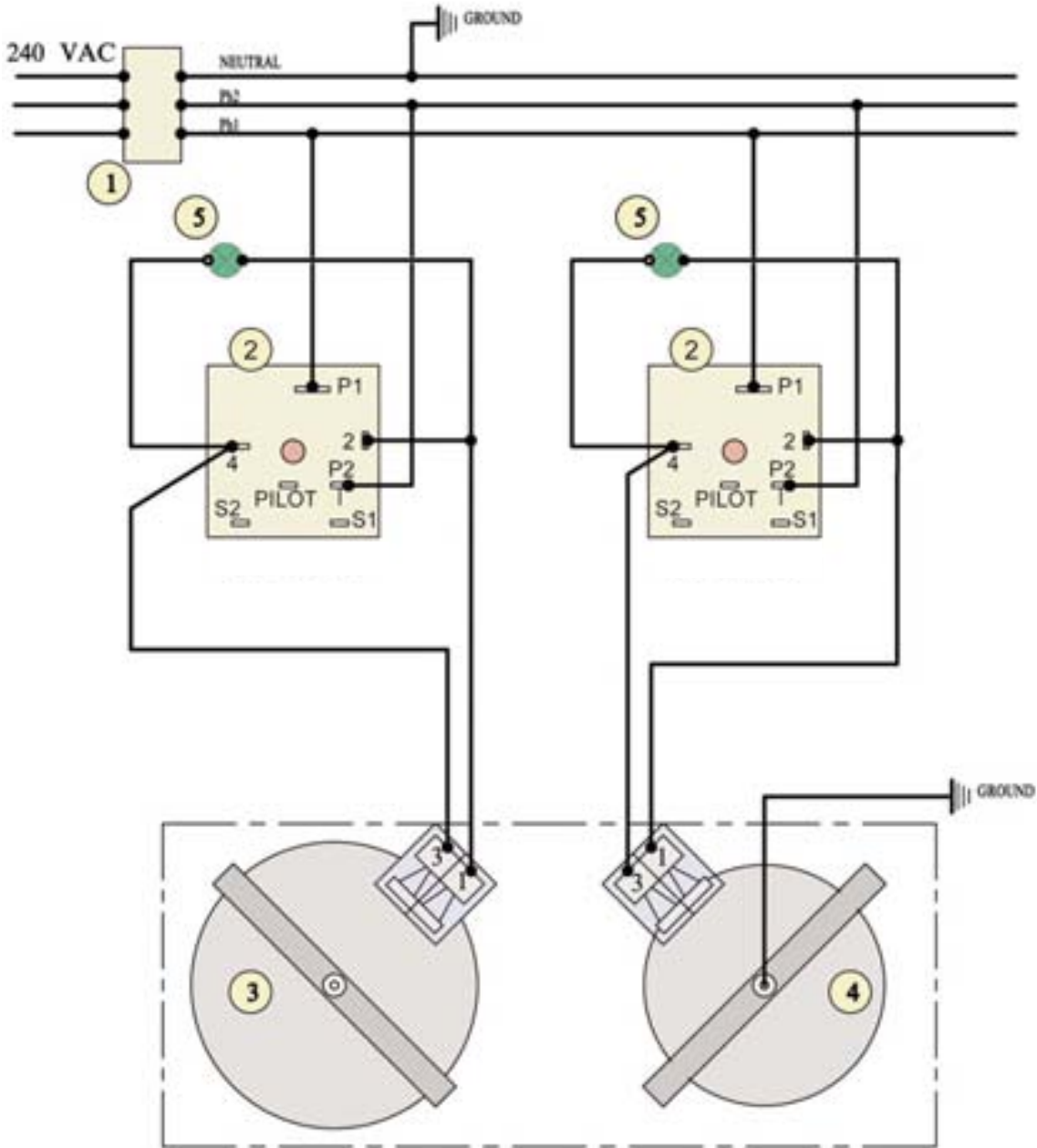

N°	Qty	Designation
1	1	Terminal block
2	2	Simmerstat
3	1	Surface Heating Element (large)
4	1	Surface Heating Element (small)
5	2	Indicator light

3. GAS OVEN WIRING - ELECTRONIC IGNITION

“CAUTION - Label all wires prior to disconnection when servicing controls.
Wiring errors can cause improper and dangerous operation.”
“Verify proper operation after servicing.”

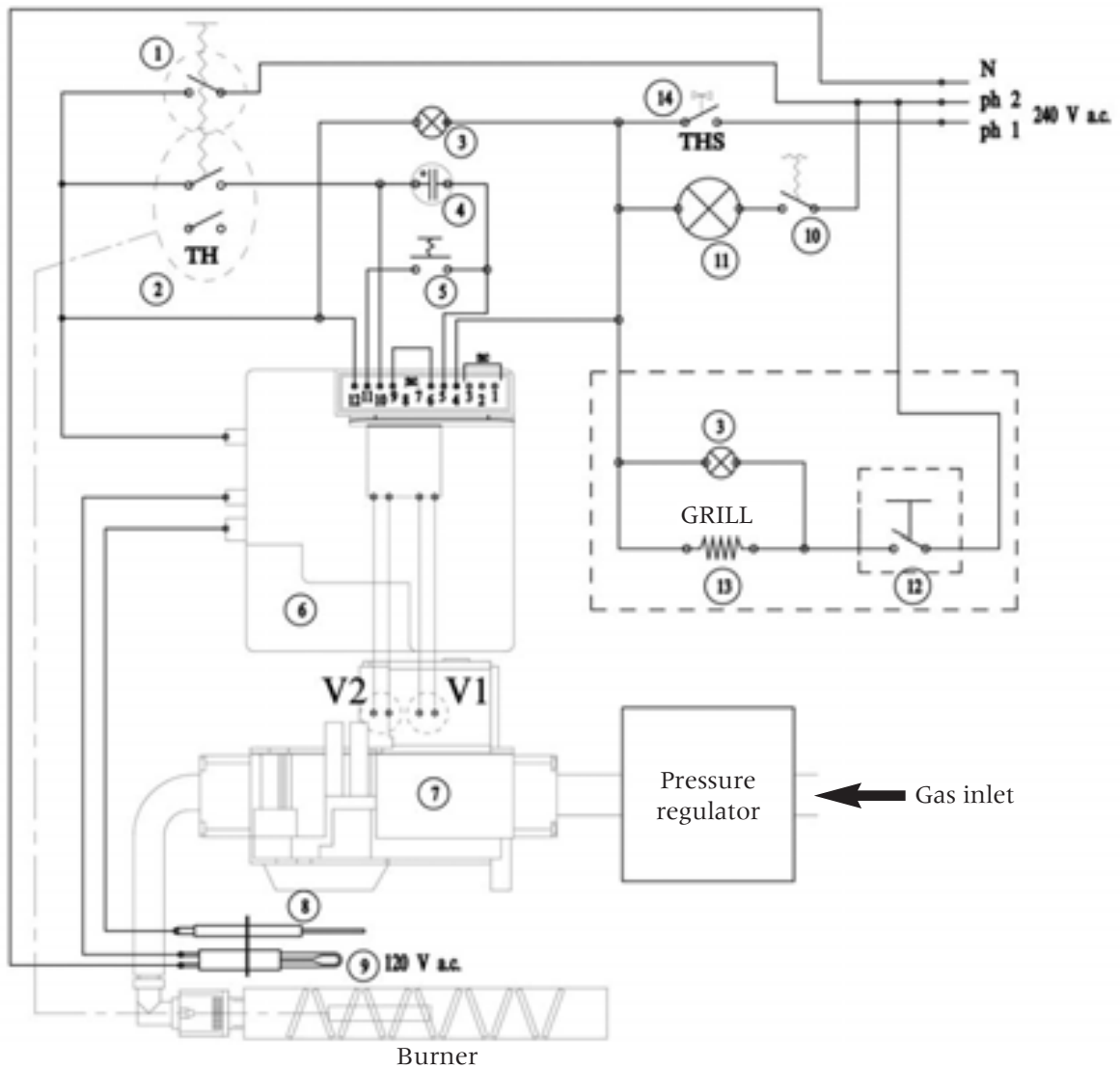

N°	Qty	Designation
1	1	ON / OFF switch
2	1	Thermostat
3	2	Green indicator light
4	1	Red indicator light
5	1	Safety reset button
6	1	Control box
7	1	Electrovalves
8	1	Sensor
9	1	Hot surface igniter
10	1	Oven light switch
11	1	Oven light
12	1	Grill simmerstat
13	1	Grill heating element
14	1	Safety thermostat

4. ELECTRIC OVEN

“CAUTION - Label all wires prior to disconnection when servicing controls. Wiring errors can cause improper and dangerous operation.”

“Verify proper operation after servicing.”

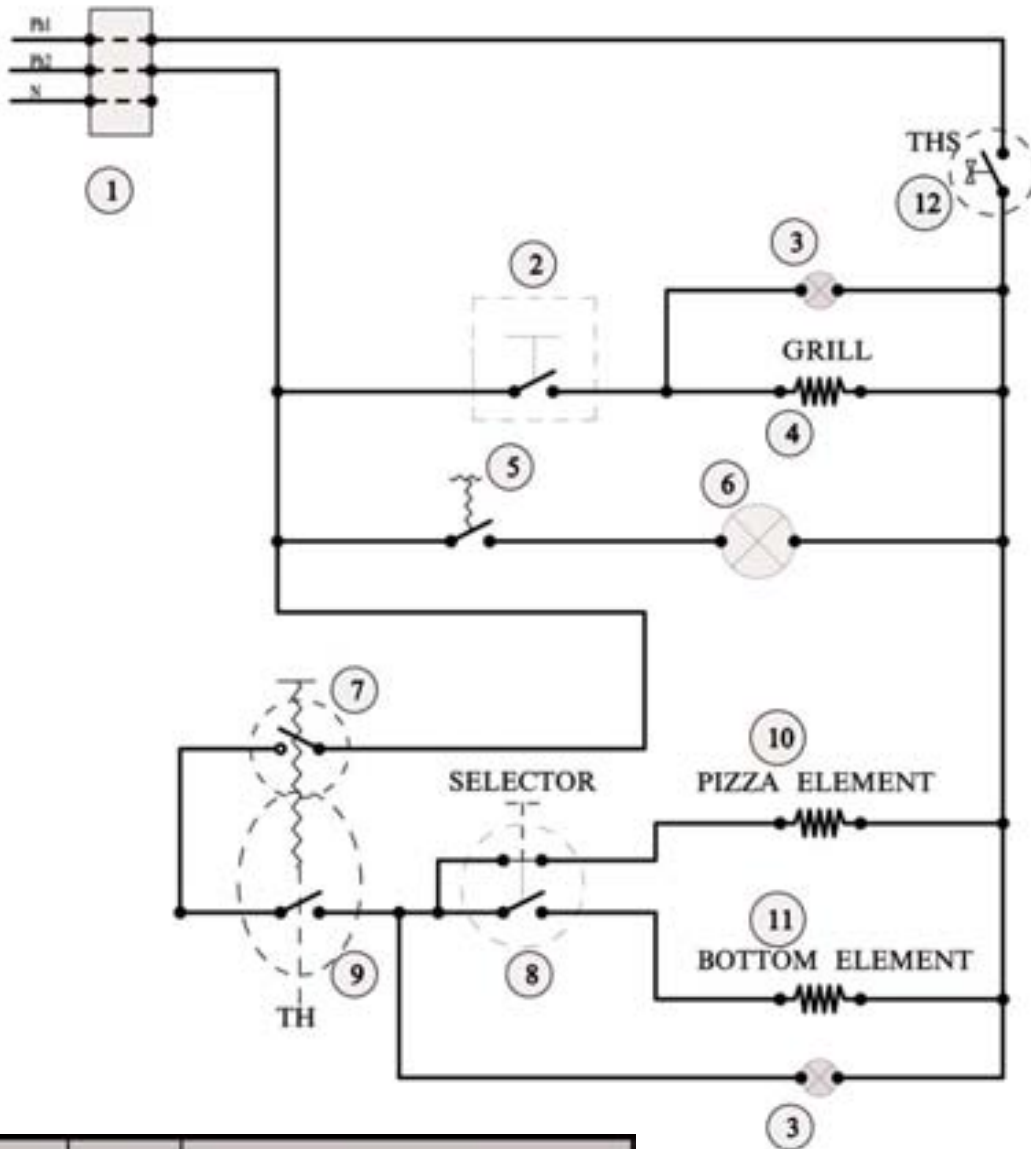

N°	Qty	Designation
1	1	Terminal block
2	1	Grill simmerstat
3	2	Green indicator light
4	1	Grill heating element
5	1	Oven light switch
6	1	Oven light
7	1	ON / OFF switch
8	1	Oven / baking stone selector
9	1	Thermostat
10	1	Baking stone heating element
11	1	Bottom heating element
12	1	Safety thermostat

WARRANTY (3 YEARS)

La Cornue company warrants to the original user for a period of three years from date of delivery not to exceed 42 months from date of shipment by Company that the product(s) manufactured by Company are free from defects in material and workmanship.

Company shall have no obligation for any product which has been misapplied, mishandled, abused, misused or subjected to harsh chemical action, or improperly installed nor to any product modified by unqualified service personnel or damaged by flood, fire or other acts of God or which has the serial number removed or altered. Adjustments such as calibrations, leveling, tightening of fasteners or utility connections normally associated with original installation are the responsibility of the dealer or installer and not that of Company.

Warranty does not cover freight charges for new or defective parts.

The liability of Company for breach of such warranty is exclusively limited to, at Company option, the replacement or repair of any part found by Company to be not as Warranted herein and, in such event replacement or repair shall be made within 36 months from the date of installation. The Company shall bear the normal labor charges in effecting such replacement or repair, to the extent that performance is effected, within 50 miles from an office of a qualified

service agency of Company except that such obligation to bear labor charges shall not apply to products or parts installed outside the United States and Canada. Replacement part(s) must be supplied by La Cornue direct or through its dealer or qualified service agency and the defective part(s) returned to same intact.

This states the exclusive remedy against Company relating to the product(s), whether in contract or in tort or under any other legal theory, and whether arising out of warranties, representations, instructions, installation or defects from any cause.

Company shall not be liable, whether in contract or in tort or under any other legal theory, for loss of use, revenue or profit, or for substitute use or performance, or incidental, indirect, or special or consequential damages, or for any other loss or cost of similar type.

This warranty and the liability set forth herein are exclusive and in lieu of all other liabilities and warranties, express or implied, including but not limited to implied warranties of merchantability and fitness for particular purpose and constitutes the only warranty of Company with the respect to product(s).

IMPORTANT INFORMATION:

When requesting information, manuals, replacement parts or service, always refer to the model and serial number of your unit. The serial plate is located behind or on the lower drawer. For your convenience space is provided below to record this information for future reference.

SERIAL No _____

MODEL No _____

DEALER _____

INSTALLATION DATE _____

Ateliers La Cornue

14, rue du Bois du Pont - Z.I. les Béthunes
95310 Saint-Ouen l'Aumône - FRANCE

Postal address:

La Cornue SAS - B.P. 99006
95070 Cergy Pontoise Cedex - FRANCE

Phone: + 33 (0)1 34 48 36 36 - Fax: + 33 (0)1 34 64 32 65

www.lacornue.com

e-mail: a.table@la-cornue.com

Purcell Murray Company:

185 Park Lane, Brisbane, CA 94005 - USA
Phone: 800-457-1356 or 415-468-6620, Fax: 415-358-4377

After-sales Service:

of 7:00 a.m. and 4:00 p.m. Pacific Time,
Monday through Friday, excluding national Holidays
by calling 877-LACORNUE

You can find these instructions on following web sites:

www.lacornueusa.com
www.purcellmurray.com



L a C o r n u e 1 9 0 8

Ateliers La Cornue

14, rue du Bois du Pont - Z.I. les Béthunes
95310 Saint-Ouen l'Aumône - FRANCE

Postal address / Adresse postale: La Cornue SAS - B.P. 99006
95070 Cergy Pontoise Cedex - FRANCE

Phone / Tél.: + 33 (0)1 34 48 36 36 - Fax: + 33 (0)1 34 64 32 65
E-mail: a.table@la-cornue.com

w w w . l a - c o r n u e . c o m