

# AlberTine 36

## Dual Fuel Range



L a C o r n u e 1 9 0 8

AlberTine

[www.la-cornue.com](http://www.la-cornue.com)

# User Guide

&

## Installation & Service Instructions

U109956 - 05A

## **Contents**

---

1. Important Safety Information	1
2. Range Overview	5
3. Multi-function Oven cooking guide	12
4. Cleaning Your Range	14
5. Troubleshooting	16
6. Installation	19
7. Conversion to LP Gas	34
8. Service and Parts	38
9. Circuit Diagram	39
10. Technical Data	40
11. Warranty	41

# 1. Important Safety Information

---

**Have your appliance properly installed and grounded by a qualified technician in accordance with the National Electrical Code ANSI/NFPA No. 70 – latest edition, and local code requirements. In Canada, electrical grounding must be in accordance with the current CSA C22.1 Canadian Electrical Code Part 1 and/or local codes.**

**Install only as described in the installation section of this book.**

**Ask your dealer to recommend a qualified technician and an authorized repair service. Know how to disconnect the power to the range at the circuit breaker or fuse box in case of an emergency.**

**The anti-tip device supplied with this range must be installed when the appliance is installed. This will reduce risk of tipping of the appliance from abnormal usage or by excessive loading of the oven door or storage drawer.**

**To avoid personal injury do not sit, stand or lean on oven doors or drawer.**

**Leaning, sitting or stepping on the doors or drawer of this range can result in serious injuries and also cause damage to the range. Do not allow anyone to climb, stand or hang on any part of the range.**

## In Case of Fire

**⚠ Do not use water on grease fires. Never pick up a flaming pan. Turn the controls off. Smother a flaming pan on a cooktop burner by covering the pan completely with a well fitting lid or baking tray. If available use a multipurpose dry chemical or foam-type fire extinguisher.**

If fire is in an oven pan, smother by closing oven door. Open doors and windows or if a hood is installed turn it on to remove smoke and odor.

## To Prevent Fire or Smoke Damage

Before using the range make sure all the packing materials have been removed.

Always keep the area around the range free from combustible materials, gasoline, and other flammable vapors and liquids.

If the range is installed near a window, proper precautions should be taken to prevent curtains from blowing over the burners.

**⚠ NEVER leave any items on the range cooktop. The hot air from an oven vent may ignite flammable items and may increase pressure in closed containers, which may cause them to burst. Many aerosol-type spray cans are EXPLOSIVE when exposed to heat and may be highly flammable. Avoid their use or storage near an appliance.**

Many plastics will burn and most are damaged by heat. Keep plastic items away from parts of the range that may become warm or hot. Do not leave plastic items on the cooktop as

they may burn, melt or soften if left too close to a vent or a lighted burner.

Storage should not be installed directly above a range. If anything is stored above the range, it should be limited to infrequently used items, which can be safely stored in an area subjected to heat from a range. Temperatures may be unsafe for some items such as volatile liquids, cleaners or aerosol sprays.

Destroy the carton and plastic bags after unpacking the range. Never allow children to play with packaging material.

Never use this appliance as a space heater to heat or warm the room. Doing so may result in overheating of the oven and control knobs.

Never cover any slots, holes or passages in the oven bottom or cover an entire rack with materials such as aluminum foil. Doing so blocks air flow through the oven. Aluminum foil linings may also trap heat causing a fire hazard.

User servicing—Do not repair or replace any part of the appliance unless specifically recommended in this User Manual.

All other servicing should be done only by a qualified technician, this may reduce the risk of personal injury and damage to the range.

Never modify or alter the construction of a range by removing leveling legs, panels, wire covers, anti-tip brackets/screws, or any other part of the product.

## **⚠ Do Not Leave Children Alone**

Babies, toddlers and young children should not be allowed near the range at any time. They should never be allowed to sit or stand on any part of the appliance.

Do not allow children to climb or play around the range. The weight of a child on an open door may cause the range to tip, resulting in serious burns or other injury.

Teach them not to play with controls or any other part of the range.

Never store items of interest to children in the cabinets above a range or on backguard of a range; children climbing on the range to reach them could be seriously injured.

## **Do not use the oven for storage.**

This instruction is based on safety considerations.

Flammable materials should not be stored in an oven, the range storage drawer or near the cooktop burners. This includes paper, plastic and cloth items, such as cookbooks, plasticware and towels, as well as flammable liquids. Do not store explosives, such as aerosol cans, on or near the appliance.

Flammable materials may explode and result in fire or property damage.

To avoid risk of electrical shock, personal injury, or death, make sure your range has been properly grounded and always disconnect it from main power supply before servicing.

Do not touch cook top burners or areas near burners.

Gas burners may be hot even if they have been off for some time. Areas near the gas burners may become hot enough to cause burns. During and after use, do not touch, or let clothing touch or other flammable materials contact the burners or areas near the burners until they have had enough time to cool. These areas include the rangetop and backguard.

### **DO NOT TOUCH HEATING ELEMENTS OR INTERIOR SURFACES OF OVENS**

Oven heating elements may be hot though they are dark in color. Interior surfaces of an oven may become hot enough to cause burns. During and after use, do not touch, or let clothing or other flammable materials touch heating elements or interior surfaces of oven until they have had enough time to cool.

Other range surfaces that may become hot enough to cause burns are the oven door and oven vent at the base of the range splashback.

### **Wear Suitable Clothing**

Never wear loose-fitting or hanging clothes while using the range. Be careful when reaching for items stored in cabinets over the cooktop. Flammable material could be ignited if brought into contact with a burner flame or hot surface and may cause severe burns.

### **Use Only Dry Potholders or Oven Gloves**

Moist or damp potholders on hot surfaces may result in burns from steam. Never let a potholder touch hot heating elements.

Do not use a towel or other bulky cloth in place of a glove. They might catch fire if they touch a hot surface.

Use dry oven gloves when applicable - using damp gloves might result in steam burns when you touch a hot surface. Never operate the range with wet hands.

### **Important Safety Notice and Warning**

The California Safe Drinking Water and Toxic Enforcement Act of 1986 (Proposition 65) requires the Governor of California to publish a list of substances known to the State of California to cause cancer or reproductive harm, and requires businesses to warn customers of potential exposures to such substances.

This appliance contains or produces a chemical or chemicals which can cause death or serious illness and which are known to the state of California to cause cancer, birth defects or other reproductive harm.

Users of this appliance are hereby warned that the burning of gas can result in low-level exposure to some of the listed substances, including benzene, formaldehyde and soot, due

primarily to the incomplete combustion of natural gas or liquid petroleum (LP) fuels. Properly adjusted burners will minimize incomplete combustion.

Exposure to these substances can also be minimized by properly venting with an open window or using a ventilation fan or hood.

To reduce the risk from substances in the fuel or from fuel combustion make sure this appliance is installed, operated, and maintained according to the instructions in this booklet.

Important: Never keep pet birds in the kitchen or in rooms where the fumes from the kitchen could reach. Birds have a very sensitive respiratory system. Fumes released due to overheated cooking oil, fat, margarine and overheated non-stick cookware may be harmful.

Important - Save the installation instructions for the local electrical inspector's use.

### **Proper Installation**

Be sure your appliance is properly installed and grounded by a qualified technician.

### **Conversion**

This appliance is supplied set for Natural gas. A conversion kit for Propane gas is supplied with the range.

Be sure your range is correctly adjusted by a qualified service technician or installer for the type of gas (Natural or LP) that is to be used. See the Installation section of these instructions.

**WARNING:** These adjustments must be made by a qualified service technician in accordance with the manufacturer's instructions and all codes and requirements of the authority having jurisdiction. Failure to follow these instructions could result in serious injury or property damage. The qualified agency performing this work assumes responsibility for the conversion.

### **User Servicing**

Do not repair or replace any part of the appliance unless specifically recommended in the manual. All other servicing should be referred to a qualified technician.

### **Cooktop burners**

#### **Quality of Flames**

On Natural Gas the burners' flames should be a blueish color with, at most, a slight yellowish fringe.

On Propane gas the flames may be "softer". The cooktop burner flames may have a slight yellowish tip.

If the flame burns with a long white tip you should call for service.

If the flame is distorted, check that the burner head is correctly placed over the burner.

**MAKE SURE THE FLOW OF COMBUSTION AND VENTILATION AIR TO THE RANGE IS UNOBSTRUCTED.**

## Use the Right Size Pan

This appliance is equipped with burners of different sizes. Use utensils with flat bottoms. Do not use unstable pans and position the handles away from the edge of the cooktop. Make sure the flames are under the pans. It's not safe to let the flames burn up the sides of the pan; the handle may get too hot.

Proper relationship of utensil to burner will also improve efficiency.

- ⚠ Never Leave Cooktop burners unattended at high settings. Pans boiling over can cause smoking and greasy spills may catch on fire.**
- ⚠ Protective Liners - Do not use aluminum foil to line cooktop bowls or oven bottoms. Foil liners may result in a risk of electric shock, or fire and will damage the enamel finish. Never allow aluminum foil to contact the heating elements.**
- ⚠ Glazed Cooking Utensils - Only certain types of glass, /ceramic, ceramic, earthenware, or other glazed utensils are suitable for range-top use without breaking due to the sudden change in temperature.**
- ⚠ Utensil handles should be turned inward and not over adjacent burners. If handles are left over adjacent burners they will get hot and may burn.**
- ⚠ Use of aluminum pans may cause metallic marking of the grates. This does not affect the durability of the enamel and may be cleaned off with a metal polish.**

## Ovens

- ⚠ Use Care When Opening Door**
- ⚠ Let hot air and steam escape before removing or replacing food.**
- ⚠ Never heat unopened food containers. Pressure build up may make container burst and cause injury.**
- ⚠ Keep oven vent ducts unobstructed.**

## Placement of Oven Racks

- ⚠ Always place oven racks in desired location while oven is cool. If rack must be moved while oven is hot, do not let potholder contact hot heating element in oven.**

### CAUTION!

- ⚠ Do not store items of interest to children in cabinets above a range or on the backguard of a range - children climbing on the range to reach items could be seriously injured.**

### WARNING!

**THIS APPLIANCE IS PROVIDED WITH ROLLERS TO FACILITATE MOVEMENT DURING INSTALLATION. THE RANGE SHOULD NOT BE MOVED AFTER INSTALLATION.**

## General Safety Instructions

This appliance must be installed by a competent person in accordance with the installation instructions. The installation must comply with the relevant regulations and also the local electricity supply company requirements.

This appliance is designed for domestic cooking only. Use for any other purpose could invalidate any warranty or liability claim.

The use of a gas cooking appliance results in the production of heat and moisture in the room in which it is installed. Ensure that the kitchen is well ventilated: keep natural ventilation holes open or install a mechanical ventilation device, (mechanical extractor hood).

Prolonged intensive use of the appliance may call for additional ventilation, for example opening a window, or more effective ventilation, for example increasing the level of mechanical ventilation where present.

The range should be serviced by a qualified service engineer and only approved parts used. Have the installer show you the location of the range circuit breaker. Mark it for easy reference. Always allow the range to cool and then switch off at the circuit breaker before cleaning or carrying out any maintenance work, unless specified otherwise in this guide.

- ⚠ All parts of the range become hot with use and will retain heat even after you have stopped cooking.**
- ⚠ Take care when touching range, to minimize the possibility of burns, always be certain that the controls are in the OFF position and that it is cool before attempting to clean the range.**

Clean with caution. If a wet sponge or cloth is used to wipe spills on a hot surface, be careful to avoid steam burns. Some cleansers can produce noxious fumes if applied to a hot surface.

Clean only parts listed in this guide.

In the interests of hygiene and safety the range should be kept clean at all times as a build up in fats and other food stuff could result in a fire.

Always keep combustible wall coverings or curtains etc. a safe distance away from your range.

**⚠ Do not spray aerosols in the vicinity of the range while it is in use.**

Do not store or use combustible materials, or flammable liquids in the vicinity of this appliance.

Take great care when heating fats and oils, as they will ignite if they get too hot.

Use a deep fat thermometer whenever possible to prevent overheating fat beyond the smoking point.

**⚠ Never leave a deep fry pan unattended. Always heat fat slowly, and watch as it heats. Deep fry pans should be only a maximum of one third full of fat. Filling the pan too full of fat can cause spill over when food is added. If you use a combination of oils or fats in frying, stir them together before heating, or as the fats melt.**

Foods for frying should be as dry as possible. Frost on frozen foods or moisture on fresh foods can cause hot fat to bubble up and over the sides of the pan. Carefully watch for spills or overheating of foods when frying at high or medium high temperatures. Never try to move a pan of hot fat, especially a deep fry pan. Wait until the fat is cool.

When an oven is on, do not use the top of the flue (the round holes along the back of the range) for warming plates, dishes, drying dish towels or softening butter.

When using an electrical appliance near the cooktop, be sure that the cord of the appliance does not come into contact with the cooktop.

Take care that no water seeps into the appliance.

Make sure that your kitchen is well ventilated at all times. Use extractor fans or hoods when installed.

The range is designed for cooking foods only and must not be used for any other purpose.

The oven should NOT be used for heating the kitchen, not only does this waste fuel but the control knobs may become overheated.

When the oven is on DO NOT leave the oven door open for longer than necessary.

The specification of this range should not be altered.

This appliance is heavy, take care when moving it.

When the range is not in use ensure that the control knobs are in the off position.

## 2. Range Overview

The dual fuel single cavity range cooker has the following features:

- A. 5 hotplate burners including a wok burner
- B. A control panel
- C. A multi-function oven
- D. A storage drawer

### Cooktop Burners

**Note:** Before using the cooktop make sure all burners are in place and all the grates on the range are properly placed.

The drawing by each knob indicates which burner that knob controls (**Fig.2-1**).

Each burner has a special Flame Safety Device (FSD) that stops the flow of gas if the flame goes out.

**When the igniter button is pressed in, sparks will be made at every burner – this is normal. Do not attempt to disassemble or clean around any burner while another burner is on, otherwise an electric shock could result.**

To light a burner, press the igniter button, and push in and turn the associated control knob to the high position as indicated by 'HI' (**Fig.2-2**).

Keep holding the knob pressed in to let the gas through to the burner for about 4 seconds (**Fig.2-3**). The igniter should spark and light the gas. When a cooktop burner knob is pressed in, sparks will be made at every burner – this is normal. Do not attempt to disassemble or clean around any burner while another burner is on. An electric shock could result.

If, when you let go of the control knob, the burner goes out, the safety device has not held in. Turn the control to the OFF position and wait one minute, then try again this time holding in the control knob for slightly longer.

Adjust the flame height to suit by turning the knob. On this range the low position is beyond high, not between high and off. The 'LO' marks the low position. Turn the knob towards it after the contents of a pan have boiled (**Fig.2-4**).

Make sure flames are under the pans. For safety reasons, adjust the flames so that they do not extend beyond the edge of the cooking utensil. This instruction is based on safety considerations (**Fig.2-5**).

Pans and kettles with concave bases or down turned base rims should not be used (**Fig.2-6**).

Simmering aids, such as asbestos or mesh mats, are NOT recommended. They will reduce burner performance and could damage the grates (**Fig.2-7**).

Avoid using unstable or misshapen pans that may tilt easily and pans with a very small base diameter e.g. milk pans, single egg poachers (**Fig.2-8**).

The minimum pan diameter recommended is 4 $\frac{3}{4}$ " (12cm) for the outer burners and 6 $\frac{3}{8}$ " (16cm) for the center burner.

**If after lighting, a cooktop burner's flame goes out, turn it off and leave it for one minute before relighting it.**

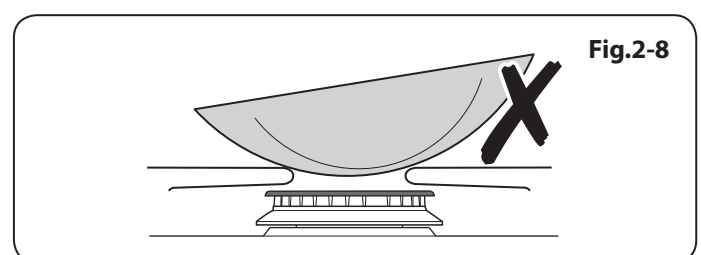
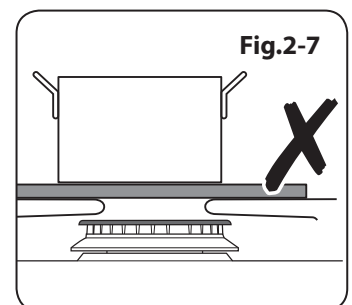
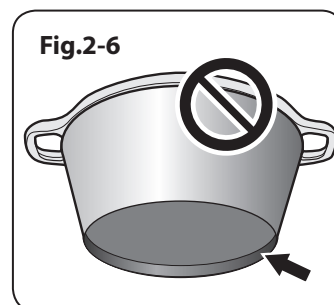
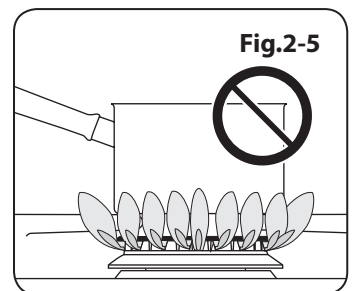
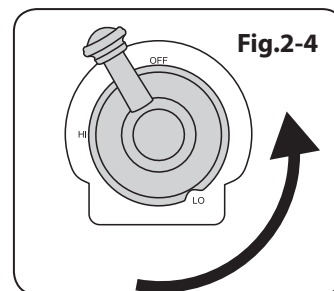
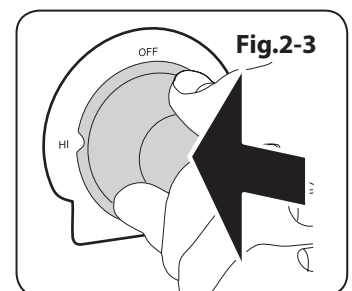
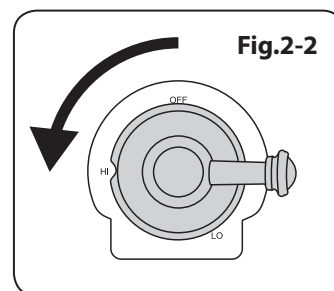
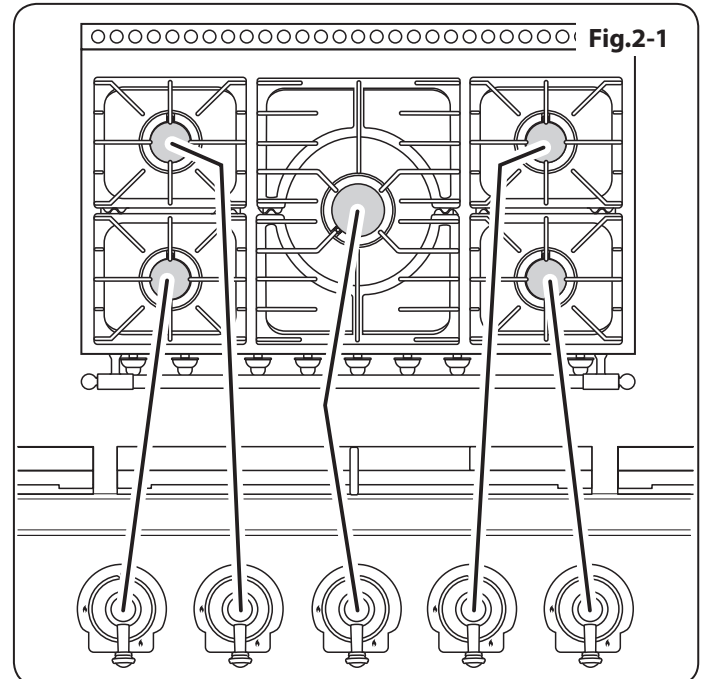

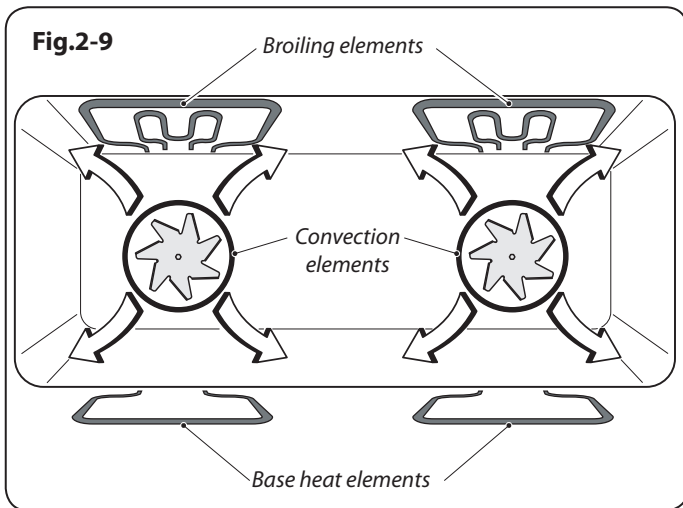

Function	Use
<b>Thaw &amp; serve</b>	To thaw small items in the oven without heat
<b>Convection oven</b>	A full cooking function, even heat throughout, great for baking
<b>Convection broiling</b>	Broiling meat and fish with the door closed
<b>Convection assisted</b>	A full cooking function good for roasting and baking
<b>Conventional oven</b>	A full cooking function for roasting and baking in the lower half of the oven
<b>Browning element</b>	To brown and crisp cheese topped dishes
<b>Warming</b>	To crisp up the bases of quiche, pizza or pastry

**Table 2-1**

## Igniting Cooktop Burners without Electricity

If there is a power failure the cooktop burners can be lit with a match.

- A.** Hold a burning match ½" from the burner head, keeping your hand as far horizontally away from the burner as possible.
- B.** Push and turn the burner control knob to HI/lighting position. As soon as the burner flame lights move your hand away. With your other hand, keep holding the knob pressed for a few seconds so that the burner safety device can 'sense' the heat of the flame.
- C.** Turn the burner control knob to the OFF position when you have finished using it.

## Cleaning

You can remove the burner head for cleaning; see the 'Cleaning your Range' section of these instructions.

**Note:** You should wipe the top surface of the range around the cooktop burners as soon as possible after spills occur.

**Note:** Use of aluminum pans may cause metallic marking of the grates. This does not affect the durability of the enamel and may be cleaned off with a metal polish.

## The Multi-function Oven

**IMPORTANT:** Before using the oven for the first time, to dispel manufacturing odors, turn the oven to 395°F (200°C) in Convection Assisted mode and run for one hour. To clear the smell make sure the room is well ventilated to the outside air, by opening windows or turning on your ventilation hood.

**During use the appliance becomes hot. Care should be taken to avoid touching the heating elements inside the oven.**

The oven is a multi-function oven (**Fig.2-9**). In addition to convection elements around the fans, it is fitted with extra heating elements, in the top of the oven and under the oven base. Take care to avoid touching the top elements when placing or removing items from the oven.

The multifunction oven has 3 main cooking functions, **convection**, **convection assisted** and **conventional cooking**. These functions should be used to complete most of your cooking.

The **browning element** and **warming** can be used in the latter part of the cooking process to fine-tune the results to your particular requirements.

Use **convection broiling** for all your broiling needs and **thaw and serve** to safely thaw small items of frozen food.

**Table 2-1** gives a summary of the multi-function modes.

The multi-function oven has many varied uses. We suggest you keep a careful eye on your cooking until you are familiar with each function. Remember, not all functions will be suitable for all food types.

Please remember that all ranges vary – temperatures in your new ovens may differ to those in your previous range.

## Operating the Oven

The multi-function oven has two controls: a function selector and a temperature setting knob (Fig.2-10).

Turn the function selector control to a cooking function.

Fig.2-11 shows the control set for conventional oven cooking.

Turn the oven temperature knob to the temperature you need. The oven heating light will glow until the oven has reached the temperature you selected. It will then cycle on and off during cooking as the oven maintains the selected temperature (Fig.2-12).

## Multi-function oven modes (Fig.2-13)

### Thaw and Serve



This function operates the fan(s) to circulate cold air only. No heat is applied. This enables small items such as desserts, cream cakes and pieces of meat, fish and poultry to be defrosted.

Thawing in this way speeds up the process and protects the food from contamination. Pieces of meat, fish and poultry should be placed on a rack, over a tray to catch any drips. Be sure to wash the rack and tray after thawing.

Thaw with the oven door closed.

Large items, such as whole chickens and meat roasts should not be thawed in this way. We recommend this be carried out in a refrigerator.

Thawing should not be carried out in a warm oven. Ensure that dairy foods, meat and poultry are completely thawed before cooking.

### Convection Oven



This function operates the fans and the heating element around them. An even heat is produced throughout the oven, allowing you to cook large amounts quickly.

Convection oven cooking is particularly suitable for multi-rack cooking and is a good 'all-round' function. It may be necessary to reduce the temperature by approximately 20°F (10°C) for recipes previously cooked in a conventional oven.

If you wish to preheat the oven, wait until the indicator light has gone out before inserting the food.

To cook on 3 levels, use racks 1, 3 and 5. Use your broiler pan and rack as an extra level.

### Convection Broiling



This function operates the fan while the top element is on. It produces a more even, less fierce heat than a conventional broiler. For best results, place the food to be grilled, on the grid in the pan provided. Thick pieces of meat or fish are ideal for cooking in this way, as the circulated air reduces the fierceness of the heat from the broiler. The oven door should be kept closed while cooking is in progress, so saving energy. You will also find that the food needs to be watched and turned less than for normal broiling.

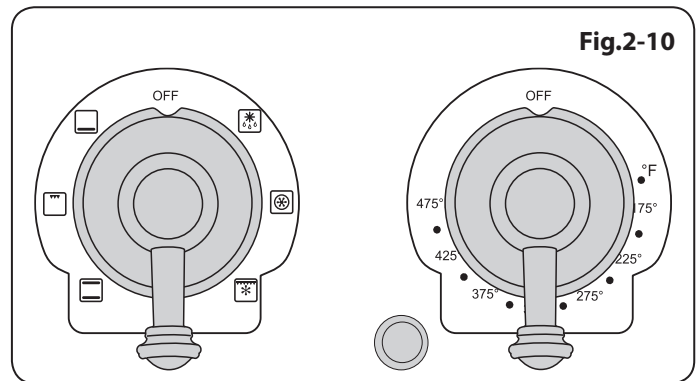

Fig.2-10

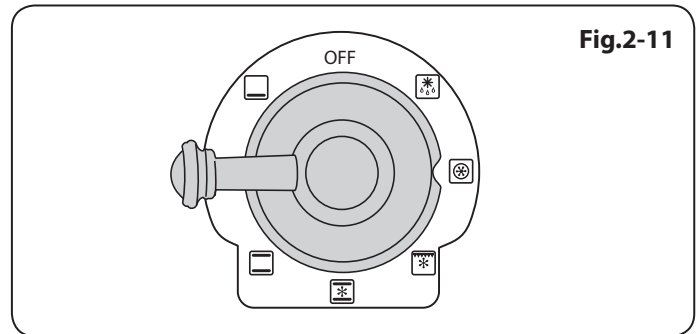

Fig.2-11

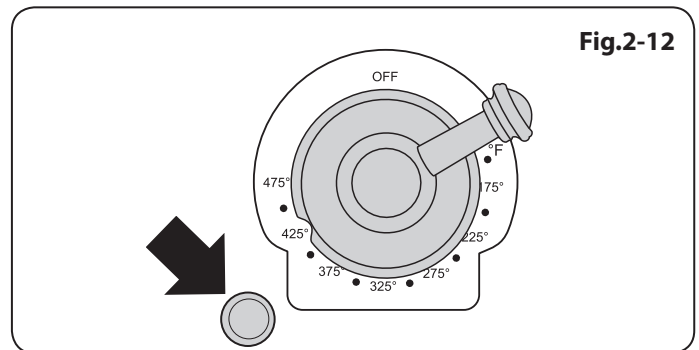

Fig.2-12

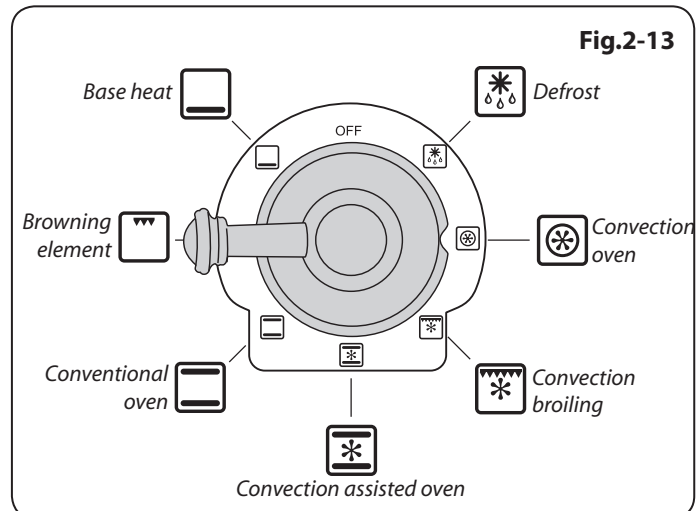
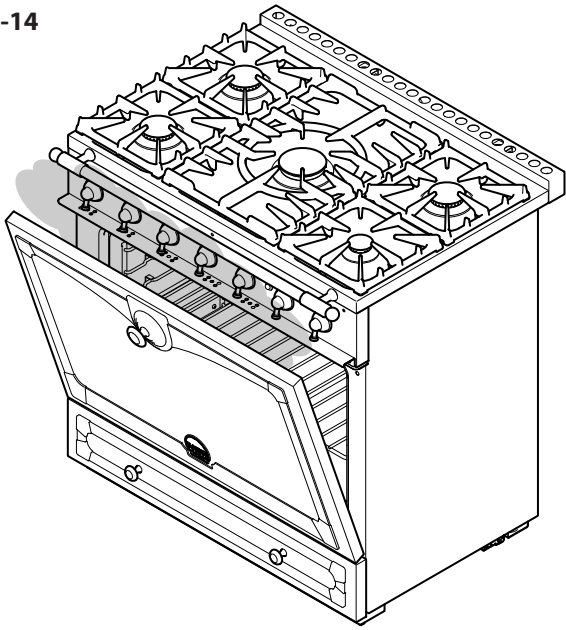

Fig.2-13

Fig.2-14



Rack levels 5 and 6 should be used depending on the size of the food being cooked.

#### **Convection Assisted Oven**



This function operates the fans, circulating air heated by the elements at the top and the base of the oven. The combination of fan and conventional cooking (top and base heat) makes this function ideal for cooking large items that need thorough cooking, such as a large meat roast. It is also possible to bake on two racks at one time using racks 2 & 4, although they will need to be changed over during the cooking time, as the heat at the top of the oven is greater than at the base, when using this function.

This is a fast intensive form of cooking; keep an eye on the food cooking until you have become accustomed to this function.

#### **Conventional Oven (Top and Base Heat)**



This function combines the heat from the top and base elements. It is particularly suitable for roasting and baking pastry, cakes and biscuits. Food cooked on the top rack will brown and crisp faster than on the lower rack, because the heat is greater at the top of the oven than at the base, as in 'Convection assisted oven' function. Similar items being cooked will need to be changed around for even cooking (use racks 2 & 4). This also means that foods requiring different temperatures can be cooked together, using the cooler zone in the lower half of the oven and hotter area to the top.

#### **Browning Element**



This function uses the element in the top of the oven only. It is a useful function for the browning or finishing of pasta dishes, vegetables in sauce and lasagne, the item to be browned being already hot before switching to the top element.

#### **Warming**



This function uses the base element only. It will crisp up your pizza or quiche base or finish off cooking the base of a pastry case on a lower rack. It is also a gentle heat, good for slow cooking of casseroles in the middle of the oven or for plate warming.

The Browning and Warming functions are useful additions to your oven, giving you flexibility to finish off items to perfection. With use, you will soon realize how these functions can combine to extend your cooking skills.

#### **Steam**

When cooking foods with high water content (e.g. oven fries) there may be some steam visible at the grille at the rear of the cooktop. This is perfectly normal.

## General Oven Tips

**IMPORTANT:** Before using for the first time, to dispel manufacturing odors turn the ovens to 395°F (200°C) in Convection Assisted mode and run for one hour. To clear the smell, make sure the room is well ventilated to the outside air, by opening windows for example.

The wire racks should always be pushed firmly to the back of the oven.

Bakeware and meat pans should be placed level centrally on the oven's wire racks. Keep all trays and containers away from the sides of the oven, as over browning of the food may occur.

Always place baking sheets with the widest part across the oven.

Cooking high moisture content foods can create a 'steam burst', when the oven door is opened. When opening the oven stand well back and allow any steam to disperse (**Fig.2-14**).

When the oven is on, do not leave the door open for longer than necessary, otherwise the knobs may get very hot.

Always leave a 'fingers width' between dishes on the same rack. This allows the heat to circulate freely around them.

Cover meat when cooking to avoid fat splashes.

To reduce fat splashing when you add vegetables to hot fat around a roast, dry them thoroughly or brush lightly with cooking oil.

If you want to brown the base of a pastry dish, preheat the baking sheet for 15 minutes before placing the dish in the center of the sheet or use the base heat in the Multifunction oven.

Where dishes may boil and spill over during cooking, place them on a baking sheet.

## Accessories

### Oven racks

Each oven is supplied with:

2 full width racks (**Fig.2-15**)

1 telescopic rack with runners (**Fig.2-16**)

One broiler pan with grid (**Fig.2-17**)

One broiler pan rack (**Fig 2-18**)

And one pastry tray (**Fig.2-19**).

Any shelf can be fitted in any of the positions. The oven shelves are retained when pulled forward but can be easily removed and refitted.

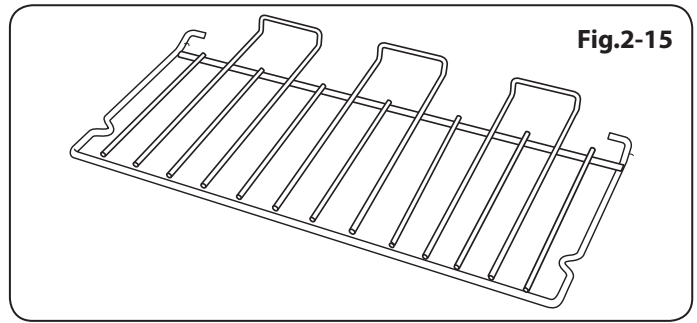

Fig.2-15

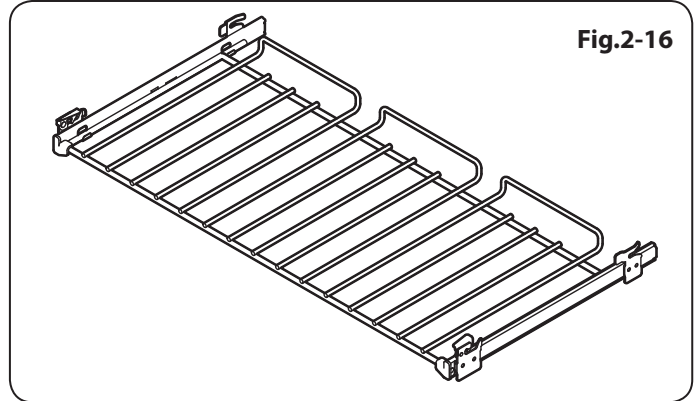

Fig.2-16

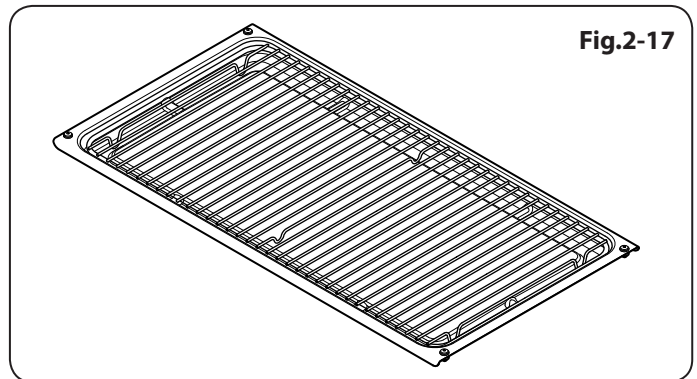

Fig.2-17

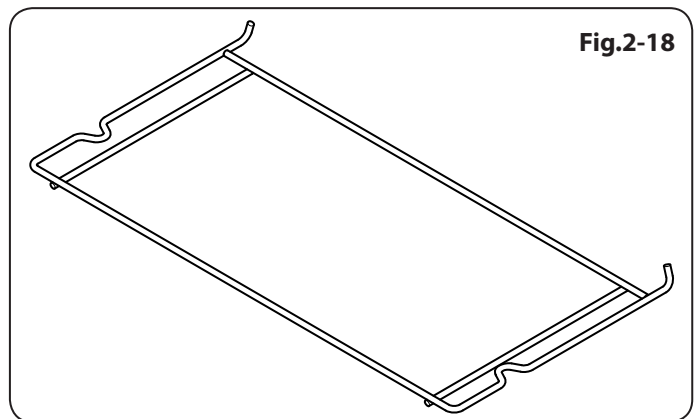

Fig.2-18

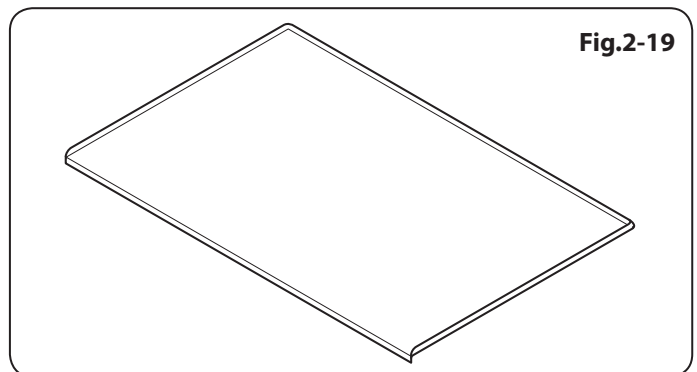
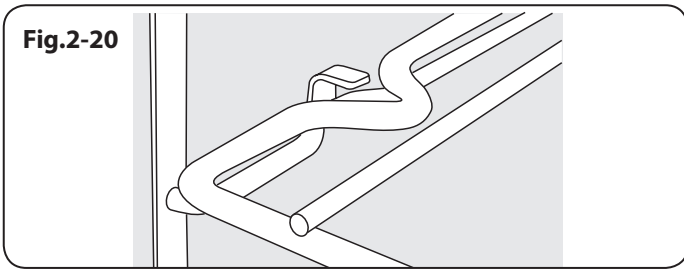

Fig.2-19



**To remove and refit the racks**

The rack has a small kink on either side (**Fig.2-20**). To remove the rack, line these up with the stops in the rack support (**Fig.2-21**). Lift the rack upwards so that it will pass over the rack stop and then pull it forwards (**Fig.2-22**).

Refit in the reverse order, making sure to push it fully back.

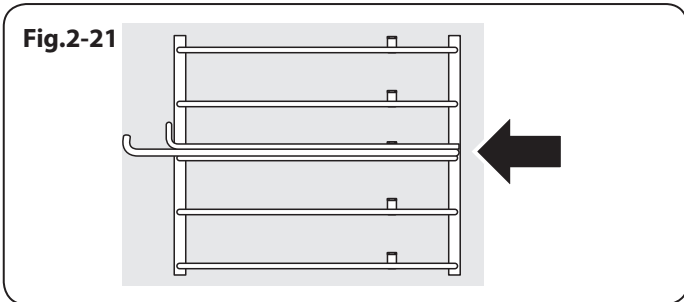

**To remove and refit the telescopic rack and runners**

Slide the rack out on the runners. While holding one of the runners securely, carefully lift the rear of the rack upwards: the rack will spring clear of the central restraining tab. Repeat for the opposite side of the rack.

**Note:** To aid the removal of the shelf you can insert a suitable flat tool through the opening in the side of the runners and lever the rack clear (**Fig.2-23**).

Tilt the front of the rack downwards and then lift clear of the runners (**Fig.2-24**).

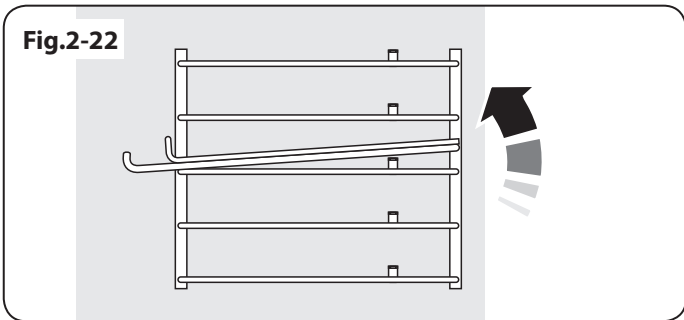

Refit in the reverse order, making sure to push the rack down onto the runner arms.

**Oven Light**

Press the appropriate button to turn on the oven lights.

If one of the oven lights fail, turn off the range circuit breaker before you change the bulb. See the 'Troubleshooting' section for details on how to change an oven light bulb (**Fig.2-25**).

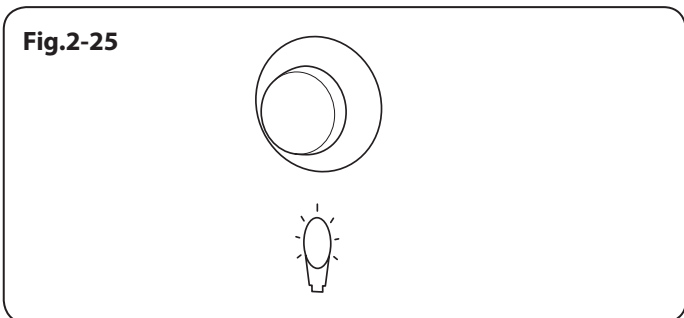
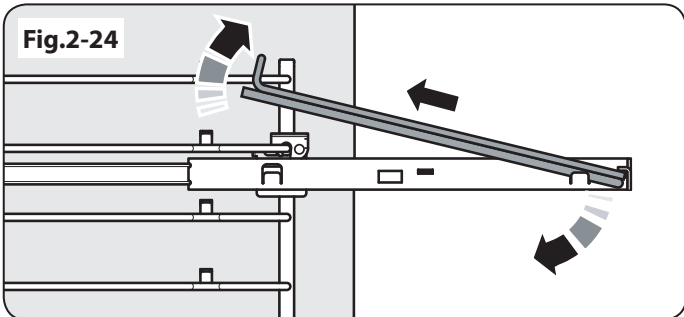
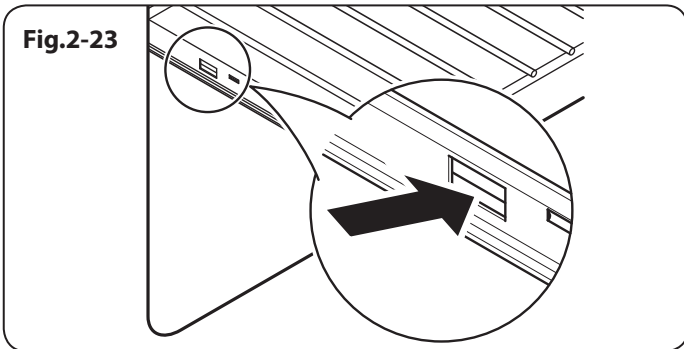

## Storage

The bottom drawer is for storing oven trays and other cooking utensils.

It can get very warm, don't store anything in it, which may melt or catch fire. Never store flammable materials in the drawer. This includes paper, plastic and cloth items, such as cookbooks, plastic ware and towels, as well as flammable liquids. Do not store explosives, such as aerosol cans, on or near the appliance.

### Flammable materials may explode and result in fire or property damage.

The drawer can be removed completely for cleaning, etc.

#### To Remove the Drawer

Pull the drawer right out (**Fig.2-26**).

Push the ends of the plastic clips – down of the left-hand side, up on the right-hand side – to release the catches holding the drawer to the side rails (**Fig.2-27**). At the same time pull the drawer forwards and away from the side rails.

For safety's sake push the drawer rails back out of the way.

#### Replace the storage drawer

To replace the drawer in the range, pull the side rails fully out (**Fig.2-28**).

At each side, hold the front of the drawer and pull the side rail forward so that the clips click into position, holding the drawer to the side rails.

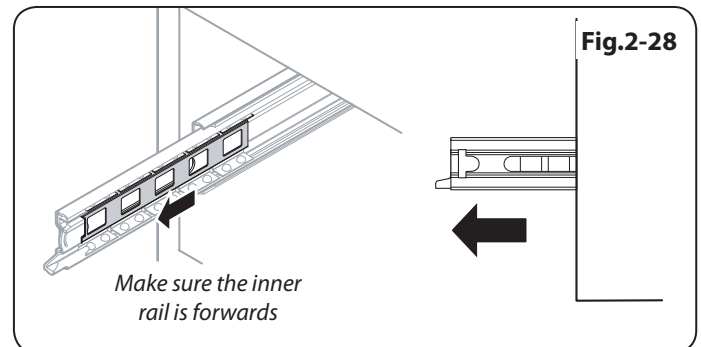
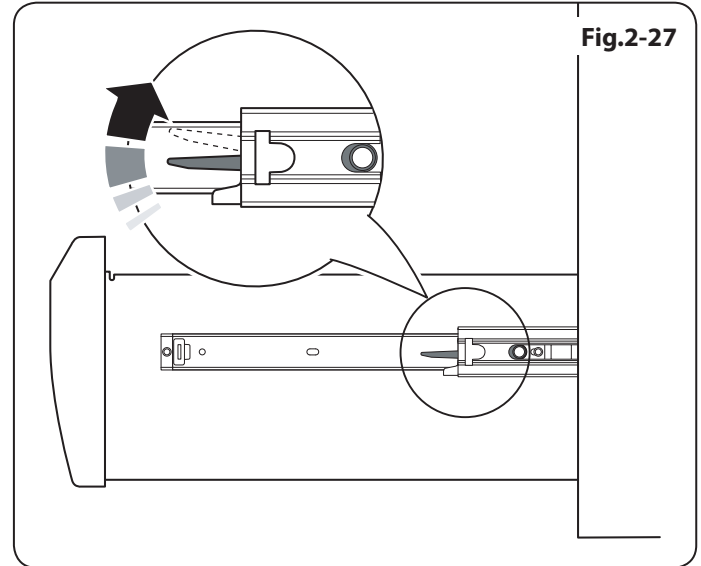
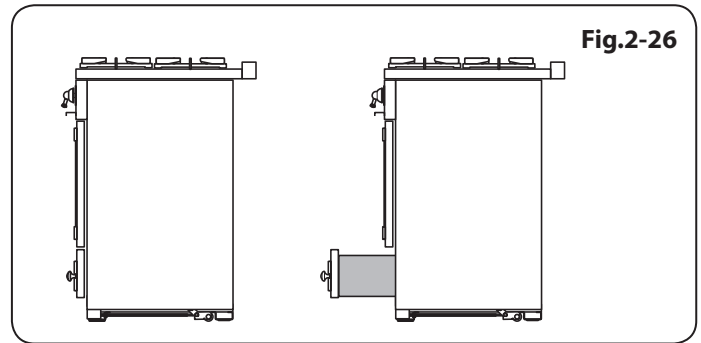

### 3. Multi-function Oven cooking guide

---

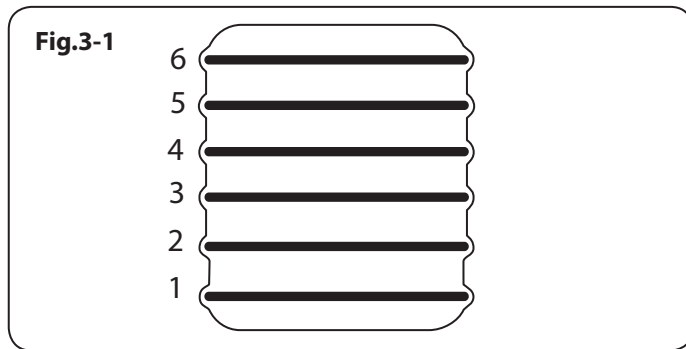

Remember – not all modes will be suitable for all food types. The oven control settings and cooking times given are intended to be used only as a guide. Individual tastes may require the temperature to be altered to provide a preferred result.



Food is cooked at a lower temperature in a convection oven than in a conventional oven. When using recipes, reduce the temperature by 20°F (10°C) and the cooking time by 5-10 minutes. The temperature in the convection oven is the same throughout ensuring uniform results.

**Fig.3-1** shows the shelf positions.

The racks should not be placed directly one above the other. When cooking on more than one rack always leave at least one runner space between them. Place baking sheets, individual cake tins or baking dishes centrally on the oven rack. For best results preheat the oven until the oven indicator light goes out.

For roast meats and poultry refer to the Convection oven guide – reduce cooking time slightly.

**⚠ Ensure meat and poultry is fully cooked before serving.**

				<i>Thoroughly thaw frozen meats and poultry before cooking. To cook on three levels, use racks 1, 3 and 5.</i>
	<b>Conventional Oven Temperature °F</b>	<b>Shelf Position</b>	<b>Convection Temperature °F</b>	<b>Approximate Cooking Time</b>
<b>Meat</b>				
Beef (no bone)	325	2-3	300	30-35 minutes per 1lb+ 30-35 minutes.
	400	2-3	375	20-25 minutes per 1lb+ 20-25 minutes.
Lamb	325	2-3	350	30-35 minutes per 1lb+ 30-35 minutes.
	400	2-3	375	20-25 minutes per 1lb+ 20-25 minutes.
Pork and veal	325	2-3	300	35-40 minutes per 1lb+ 35-40 minutes.
	400	2-3	375	25-30 minutes per 1lb+ 25-30 minutes.
<b>Poultry</b>				
Chicken	325	3-4	300	20-25 minutes per 1lb+ 20-25 minutes.
	400	3-4	375	15-20 minutes per 1lb+ 15-20 minutes.
Turkey	325	3-4	300	25-30 minutes per 1lb+ 25-30 minutes.
	400	3-4	375	20 minutes per 1lb+ 20 minutes.
Turkey	325	4	300	20 minutes per 1lb+ 20 minutes.
	400	4	375	15 minutes per 1lb+ 15 minutes.
Duck / duckling	325	4	300	20 minutes per 1lb.
<b>Casserole</b>	300-325	2-3	300	2-4 hours according to recipe.
<b>Fish</b>				
	375	3	350	Fillet 15-20 minutes. Whole 15-20 minutes per 1lb.
	375	3	350	Whole 10 minutes per lb + 10 minutes.
	375	3	350	Steaks according to thickness.
<b>Cake</b>				
Very rich fruit cake	300	2	275	45-50 minutes per 1lb of mixture.
Fruit 7" tin	300	4	275	2-2.5 hours.
Fruit 9" tin	325	2 & 4 or 3	300	Up to 3.5 hours.
Madeira 7" tin	375	2 & 4 or 3	350	80-90 minutes.
<b>Desserts</b>				
Cup Cake	350	2-4	340	20 minutes.
Scone	400	2-4	375	15 minutes.
Deep Apple Pie	375	2-4	350	45 minutes interchange after 25 minutes.
Plate Tart	375	3	350	45 minutes interchange after 25 minutes.
Fruit cake 8" x 3.5"	300	3	275	1 hour 45 minutes - 2 hours.
Puff Pastry	450	3-5	425	15-40 minutes according to size interchange <sup>2</sup> / <sub>3</sub> through cooking time.
Angel Food Cake	350	3	325	50-60 minutes.
Brownies	375	2-4	350	25-30 minutes interchange after 15 mins.
Muffins	375	2-4	350	25-30 minutes interchange after 15 mins.
Cookies	375	2-4	350	10-15 minutes interchange after 8 mins.
Pound Cakes	375	3	350	40-60 minutes.
<b>Bread</b>	425	3	400	20-30 minutes.

## 4. Cleaning Your Range

Part	Finish	Recommended cleaning method
Burner grates & top of burner heads	Porcelain enamel	Mildly abrasive cleaner such as Bon Ami® or Soft Scrub®. Dishwasher.
Burner base	Aluminum	As above.
Maintop top	Stainless steel	Hot soapy water, non-abrasive cleaner, soft cloth.
Sides, toe-kick	Painted enamel	Hot soapy water and soft cloth.
Control panel	Porcelain enamel or stainless steel	Non-abrasive cleaner, soft cloth.
Oven interior	Porcelain enamel	Branded oven cleaner suitable for enamel surfaces such as Dawn Power Dissolver®. Take care not to damage the oven door seals.
Door handles	Brass or plated brass/plastic	Non-abrasive cleaner, hot soapy water, soft cloth. Brass handles can be cleaned with a gentle brass polish.
Oven racks & supports	Chrome	Dishwasher. Hot soapy water and scouring pad.
Door inner	Porcelain enamel	Mildly abrasive cleaner such as Bon Ami® or Soft Scrub® with a soft cloth.
Outer door and drawer	Porcelain enamel or stainless steel	Multi-surface cleaner, soft cloth.
Brass trims (some models only)	Brass	Non-abrasive cleaner, hot soapy water, soft cloth. Gentle brass polish.
Copper trims (some models only)	Copper	Hot soapy water and soft cloth.
Oven Liner	Porcelain Enamel	Mildly abrasive cleaner such as Bon Ami® or Soft Scrub® with a soft cloth.

Table 4-1

### Essential Information

Before thorough cleaning, turn off the circuit breaker. Allow the range to cool.

After cleaning remember to switch on the circuit breaker before using the range.

**Never use paint solvents, caustic cleaners, biological powders, bleach, chlorine based bleach cleaners, coarse abrasives or salt. Do not mix different cleaning products – they may react together with hazardous results.**

Recommended cleaning materials are shown in **Table 4.1**.

### Cleaning the Range – Daily Care

Cleaning the range is not a welcomed chore, but it has to be done to maintain efficiency and appearance. Remember it is better to wipe up any spills as they occur, this will prevent them burning on and becoming more difficult to remove later.

**⚠ Make sure the flow of combustion and ventilation air to the range is unobstructed – for example by build-up of fats or grease.**

If the flame is distorted, check that the burner head is correctly placed over the burner base (**Fig.4-1**).

If the flame burns with a long white tip you should call for service.

### Cleaning for Spills

For spills and boil-overs that occur while cooking, as soon as possible turn off the burner and allow it to cool. Do not clean until the area is completely cooled down. Wipe up spills as soon as possible.

Do not allow surplus water to seep into the range.

### Cooktop Burners

The burner heads and caps can be removed for cleaning. Make sure they are absolutely dry before replacing.

When replacing burner head, ensure this locates properly within the base (**Fig.4-2**).

If you look at the bottom of the burner head you will see two 'pips'; these fit into the two notches in the burner base (**Fig.4-3**).

Check burner ports are not blocked. If blockage occurs, remove stubborn particles using a piece of fuse wire.

### Stainless Steel Main Top

Lift away pots or pans from main top. Remove grates from spillage area and carefully place in a sink of warm soapy water. Wipe loose debris from main top. Avoid using any abrasive cleaners including cream cleaners on brushed stainless steel surfaces. For best results use a liquid detergent cleaner. Rinse with cold water and thoroughly dry with a clean, soft cloth. Ensure all parts are dry before repositioning.

**⚠ Never use caustic or abrasive cleaners as these will damage the surface.**

## Control Panel and Oven Doors

Avoid using any abrasive cleaners including cream cleaners, on brushed stainless steel surfaces. For best results use liquid detergents.

The control panel and control knobs should only be cleaned with a soft cloth wrung out in clean hot soapy water – but take care that no surplus water seeps into the appliance. Wipe with a clean dampened cloth then polish with a dry cloth. The oven doors should only be cleaned with a soft cloth wrung out in clean hot soapy water.

## Cleaning Brass Parts (some models only)

Uncoated natural brass is used as part of the authentic finish on some models and this may tarnish with age. To regain a polished finish, these areas should be cleaned using a gentle brass cleaner. Take care the cleaner does not affect surrounding areas.

## Ovens

The side panels can be removed for cleaning and for cleaning behind them.

## Removing the Oven Linings

Remove the shelves first. To remove the oven shelf supports lift until clear of the two supporting holes and pull outwards (**Fig 4-4**).

Please note – there are specific liners for the left and right hand side.

To remove the side panels, simply lift the panel and slide forwards (**Fig 4-5**).

## Replacing the Oven Linings

To replace the liner the cut-out section must be at the top of the liner. Slide the liner towards the back of the oven cavity. When this is in place the shelf supports can be replaced. To do this, first insert the bottom of the support in the cut-out followed by the two hooks at the top.

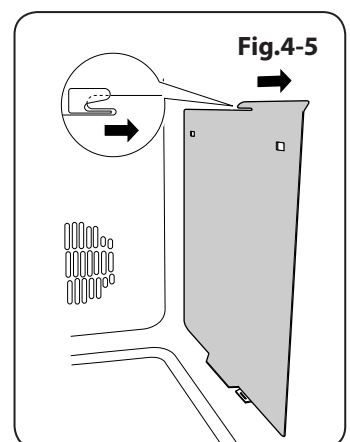
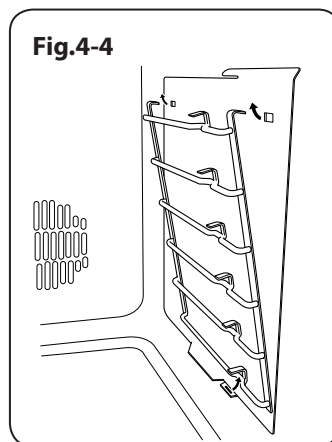
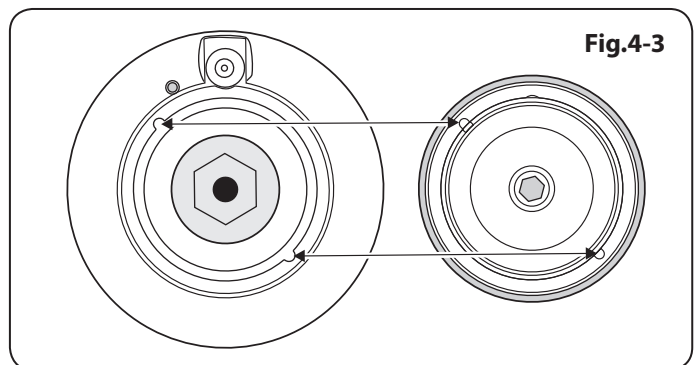
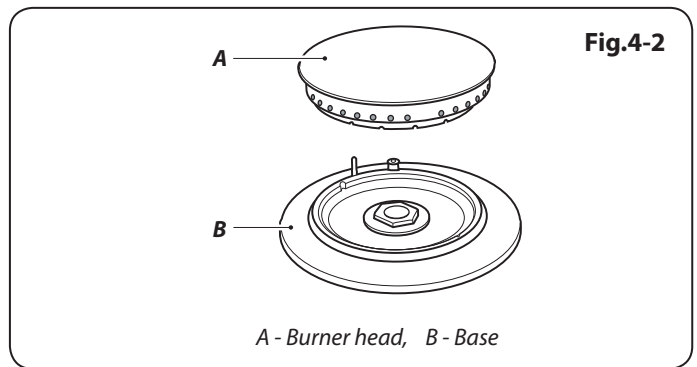
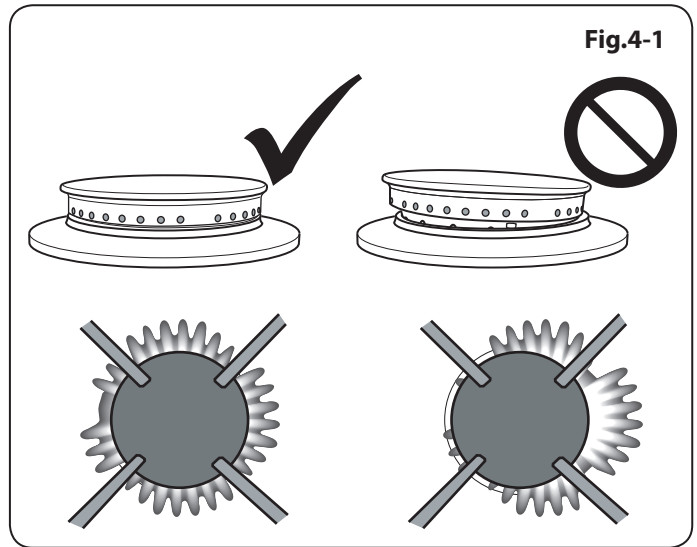

## 5. Troubleshooting

---

### Cooktop ignition or cooktop burners faulty

Is the power on?

Are the sparker (ignition electrode) or burner holes blocked by debris?

Are the burner heads correctly located? See the section entitled 'Cleaning'.

Remember that each cooktop burner has a special safety device that stops the flow of gas if the flame goes out. When lighting a cooktop burner the safety device has to be overridden by holding in the control knob so that the gas can flow. This allows the flame sensor to heat up and operate the safety device. Keep holding the knob pressed in to let the gas through to the burner for few seconds. The igniter should spark and light the gas.

If, when you let go of the control knob, the burner goes out, the safety device has not held in. Turn the control to the off position and wait one minute, then try again this time holding in the control knob for slightly longer.

### Cooktop burners will not light

If only one or all the cooktop burners will not light, make sure that the parts have been replaced correctly after wiping or removing for cleaning.

Check that there is not a problem with your gas supply. You can do this by making sure that other gas appliances you may have are working.

Do the burners spark when you push in the control knob? If not check the power is on.

### Steam is coming from the oven

When cooking foods with a high water content (e.g. oven fries) there may be some steam visible at the rear grille. Take care when opening the oven door, as there may be a momentary puff of steam when the oven door is opened. Stand well back and allow any steam to disperse.

### An oven fan is noisy

The sound of the oven fan may change as the oven heats up – this is perfectly normal.

### What cleaning materials are recommended for the range?

See the 'Cleaning' section for a full list of recommended cleaning materials.



**do not recommend corrosive or caustic cleaners as these may damage your range.**

### The knobs get hot when I use the oven, can I avoid this?

Yes, this is caused by heat rising from the oven, and heating them up. Do not leave the oven door open.

### If there is an installation problem and I don't get my original installer to come back to fix it who pays?

You do. Service organizations will charge for their

service if they are correcting work carried out by your original installer. It is in your interest to track down your original installer.

### Current Operated Ground Fault Circuit Breaker

Where the range installation is protected by a 30 mA sensitivity residual current device (RCD), the combined use of your range and other domestic appliances may occasionally cause nuisance tripping.

### Food is cooking too slowly, too quickly, or burning

Cooking times may differ from your previous oven. Check that you are using the recommended temperatures and rack positions. See the oven cooking guide section of the instructions. The oven control settings and cooking times are intended to be used only as a guide. Individual tastes may require the temperature to be altered either way, to get the results you want. Try cooking at a higher temperature setting.

### The oven is not cooking evenly

If you are cooking a large item, be prepared to turn it round during cooking.

If two racks are used, check that space has been left for the heat to circulate. When a baking sheet is put into the oven, make sure it is placed centrally on the rack.

Check that the door seal is not damaged.

A dish of water when placed on the rack should be the same depth all over. (For example, if it is deeper at the back, then the back of the range should be raised up or the front lowered).

If the range is not level arrange for your supplier to level it for you.

### Oven not coming on

Is the power on?

If not there may be something wrong with the power supply. Is the range supply on at the circuit breaker?

Have you set a cooking function?

### Oven temperature getting hotter as the range gets older

If turning the knob down has not worked or only worked for a short time then you may need a new thermostat. This should be installed by a service technician (see the 'Service and Parts' section of the instructions).

### An oven light is not working

The bulb has probably burnt out. You can buy a replacement bulb (which is not covered under the warranty) from a good electrical shop. Ask for a 15W 125–130V lamp, FOR OVENS. It must be a special bulb, heat resistant to 570°F (300°C) (**Fig.5-1**).

Turn off the power at the circuit breaker.

Make sure the oven is cool. Open the oven door and remove the oven racks.

Unscrew the bulb cover by turning counter clockwise. It may be very stiff (**Fig.5-2**).

Taking care to protect your fingers in case the bulb should shatter, unscrew the old bulb.

Screw in the new bulb; screw back the bulb cover. Turn on the circuit breaker and check that the bulb now lights.

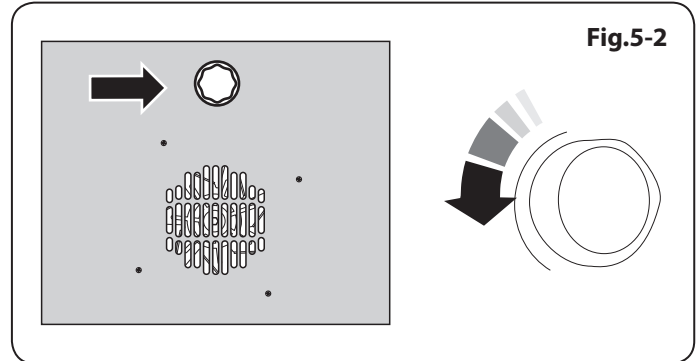
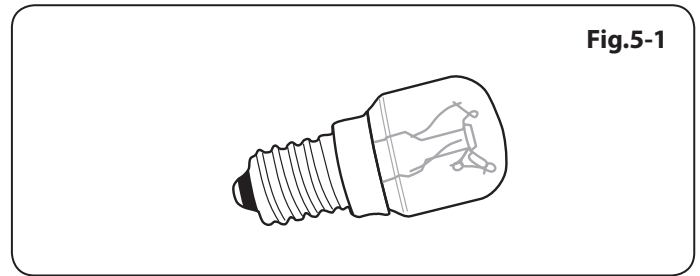

# WARNING!

If the information in this manual is not followed exactly, a fire or explosion may result causing property damage, personal injury or death.

**Do not store or use gasoline or other flammable vapors and liquids in the vicinity of this or any other appliance.**

## WHAT TO DO IF YOU SMELL GAS

**Do not try to light any appliance.**

**Do not touch any electrical switch.**

**Do not use any phone in your building.**

**Immediately call your gas supplier from a neighbor's phone. Follow the gas supplier's instructions.**

**If you cannot reach your gas supplier, call the fire department.**

**Installation and service must be performed by a qualified installer, service agency or the gas supplier.**

# WARNING!

The anti-tip device supplied with this range must be installed when the appliance is installed. This will reduce risk of tipping of the appliance from abnormal usage or by excessive loading of the oven door or storage drawer.



## ⚠ WARNING!

- ALL RANGES CAN TIP
- INJURY TO PERSONS COULD RESULT
- INSTALL ANTI-TIP BRACKET PACKED WITH RANGE
- SEE INSTALLATION INSTRUCTIONS

## 6. Installation

### Regulations

Installation of this range must conform with local codes, or in the absence of local codes, with the National Fuel Gas Code, ANSI Z223.1/NFPA.54, latest edition.

In Canada, installation must conform with the current Natural Gas Installation Code, CAN/CGA-B149.1 or the current Propane Installation Code, CAN/CGA-B149.2, and with local codes where applicable.

This range has been design-certified by CSA International according to ANSI Z21.1, latest edition and CAN/CGA-22.2 latest edition.

Read the instructions before installing or using this appliance. This range becomes hot in use, the cooktop burners produce exhaust gases.

The range must be electrically grounded in accordance with local codes or, in the absence of local codes, in accordance with the National Electrical Code (ANSI/NFPA 70, latest edition). In Canada, electrical grounding must be in accordance with the current CSA C22.1 Canadian Electrical Code Part 1 and/or local codes. See 'Electrical Connection' in this section.

### Important

- Observe all governing codes and ordinances.
- The range must be properly grounded.
- Save these instructions for the local electrical inspector's use.

### For Your Safety

Do not store or use combustible materials, gasoline or other flammable vapors and liquids in the vicinity of this or any other appliance.

#### *If you smell gas*

- Open windows.
- Do not touch electrical switches.
- Extinguish any open flame.
- Immediately call your gas supplier

### Installation Safety Instructions

- ⚠ **Improper installation, adjustment, alteration, service or maintenance can cause injury or property damage. Refer to this manual. For assistance or additional information, consult a qualified installer, service agency, manufacturer (dealer) or the gas supplier.**
- ⚠ **Never reuse old flexible connectors. The use of old flexible connectors can cause gas leaks and personal injury. Always use NEW flexible connectors when installing a gas appliance.**

### Important

- Remove all packing material and literature from oven before connecting gas and electrical supply to range.
- Have your range installed by a qualified installer.
- Your range must be electrically grounded in accordance with local codes or, in the absence of local codes, in accordance with the National Electrical Code (ANSI/NFPA 70, latest edition).
- Before installing your range on linoleum or any other synthetic floor covering, make sure the floor covering can withstand 180°F (80°C) without shrinking, warping or discoloring. Do not install the range over carpeting unless a sheet of ¼" thick plywood or similar insulator is placed between the range and carpeting.
- Make sure the wall coverings around the range can withstand heat generated by the range up to 200°F (90°C).
- Avoid placing cabinets above the range. There must be a gap of at least 31½" (80cm) between the top of the range and any combustible surface above it.
- If a ventilating hood is installed above the range follow the installation instructions supplied with the hood.
- ⚠ **Items of interest to children should not be stored above a range – children climbing on the range to reach items could be seriously injured.**

### Converting to Propane Gas

This appliance is supplied set for Natural gas.

A conversion kit for Propane gas is supplied with the range.

If the appliance is to be converted this must be done before installation. The conversion must be performed by a qualified LP gas installer. See the Conversion section at the back of this installation manual for more details.

## INSTALLATION

**Check the appliance is electrically safe and gas sound when you have finished.**

### Location of the Range

Do not locate the range where it may be subject to strong drafts. Any openings in the floor or wall behind the range should be sealed. Make sure the openings around the base of the range that supply fresh air for combustion and ventilation are not obstructed by carpeting or woodwork.

Your range is heavy and can settle into soft floor coverings such as cushioned vinyl or carpeting. Use care when moving the range on this type of flooring. It is recommended that the following instructions be followed to protect your floor.

The range should be installed on a sheet of plywood (or similar material). When the floor covering ends at the front of the range, the area that the range will rest on should be built up with plywood to the same level or higher than the floor covering.

This will allow the range to be moved for cleaning or servicing. Also, make sure your floor covering will withstand 180°F (80°C); see the 'Installation Safety Instructions' section.

Make sure the wall coverings around your range can withstand the heat generated, up to 200°F (90°C), by the range; see the 'Installation Safety Instructions' section.

#### **You will also need the following tools:**

1. Electric drill
2. Masonry drill bit & anchors (only required if installing the range on a stone or concrete floor)
3. Steel tape measure
4. Phillips head screwdriver
5. Flat head screwdriver
6. 2.5 mm Allen key (supplied with the range)
7. Level
8. Open-end or adjustable wrench
9. Pencil and ruler
10. Pipe wrenches

#### **Additional materials you may need:**

- Gas line shut-off valve
- Pipe joint sealant or UL-approved pipe thread tape with Teflon\* that resists action of natural and LP gases.
- Flexible metal appliance connector (½" I.D.). A 5 foot length is recommended for ease of installation but other lengths are acceptable. Never use an old connector when installing a new range.
- Flare union adapter for connection to gas supply line (¾" or ½" NPT x ½" I.D.)
- Flare union adapter for connection to pressure regulator on range (½" NPT x ½" I.D.)
- To protect any floor covering under the range a sheet of ¼" thick plywood or equivalent large enough to stand the range on.

### Checking the parts:

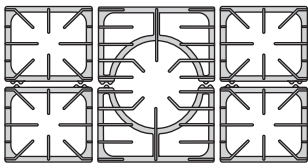
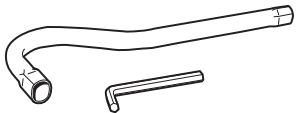
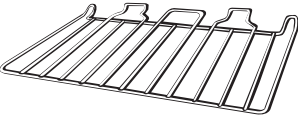
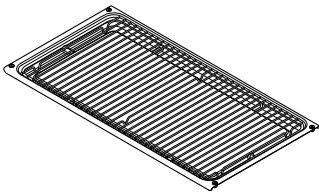
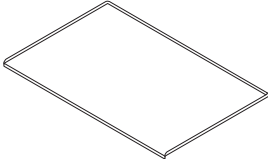
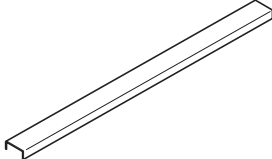
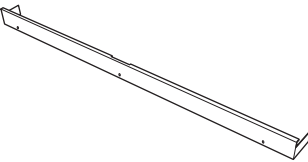
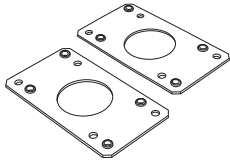
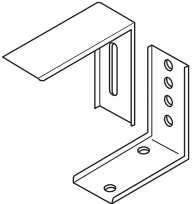
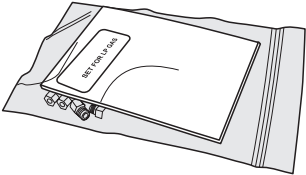
6 grates	Leveling tool and Allen key
	
1 full capacity shelf	Broiler tray and grid
	
1 pastry tray	Side extension kit
	
Toe kick	Reducer plates for conduit connection
	
Anti-tip device	Conversion kit from natural gas to propane gas
	

## INSTALLATION

**Check the appliance is electrically safe and gas sound when you have finished.**

### Positioning the Range

**Fig.6-1** and **Fig.6-2** show the minimum recommended distances and clearances from the range to nearby surfaces.

You must provide adequate clearances between the range and adjacent combustible surfaces. These dimensions must be met for safe use of your range.

The location of the electrical outlet and pipe opening (see Gas Pipe and Electric Outlet Locations) may be adjusted to meet specific requirements.

A gap of at least 3" (7.5 cm) should be left between each side of the range **ABOVE** the cooktop level and any adjacent vertical surface.

The cooktop surround should be level with, or above, any adjacent work surface.

For non-combustible surfaces (such as unpainted metal or ceramic tiles) the gap each side can be reduced from 3" to 1" (2.5 cm).

A minimum space of 31½" (80 cm) is required between the top of the cooktop and a horizontal combustible surface. The maximum depth for cabinets installed above cooktops is 13" (33 cm).

The depth of the range is 28⅜" (72 cm) overall (**Fig.6-3**).

Any range hood should be installed in accordance with the hood manufacturer's instructions.

For safety reasons curtains must not be sited immediately behind the range.

We recommend a gap of 35½" (90 cm) – 36" (91 cm) (for Canada 36⅜" (92.5 cm)) between units to allow for moving the range.

If a flush fit is required (USA only), install the range up to the unit at one side then install the unit the other side.

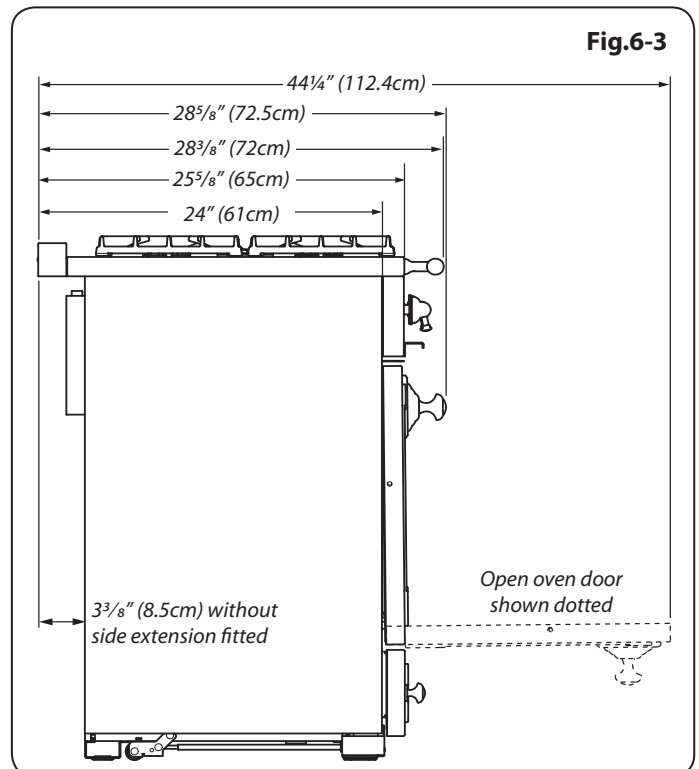
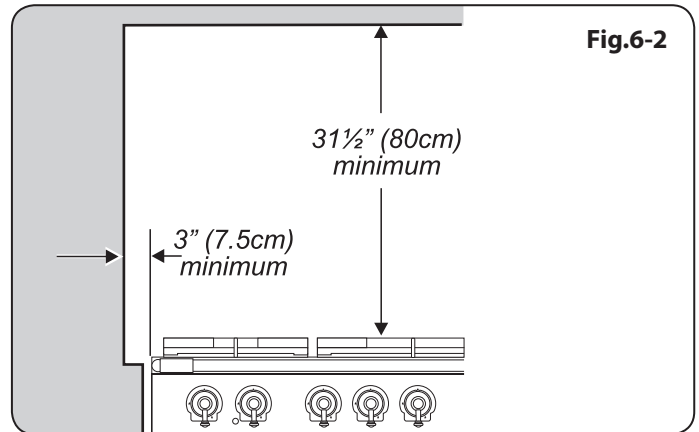
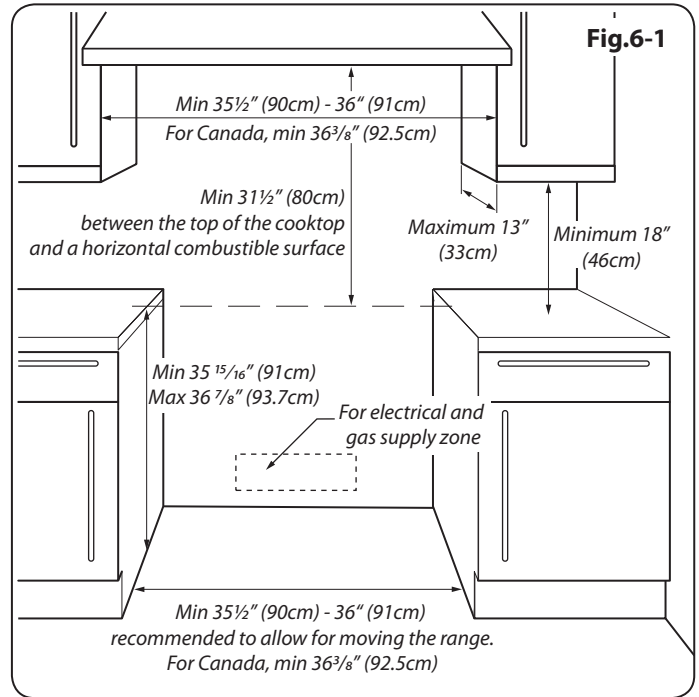

## INSTALLATION

Check the appliance is electrically safe and gas sound when you have finished.

Fig.6-4

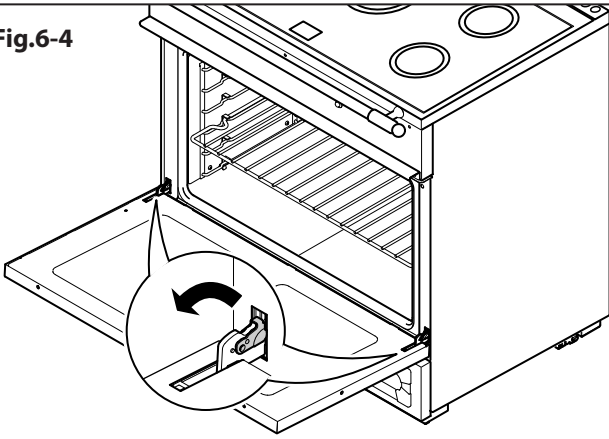

### Moving the Range

**⚠ The range is very heavy. Take great care.**

We recommend two people maneuver the range. Ensure that the floor covering is firmly attached, or removed to prevent it being disturbed when moving the range around. You will need the leveling tool.

### Removing the door

Remove the oven door as follows: open the door fully. Swivel the locking 'U' clips forward to the locking position (**Fig.6-4**). To remove the oven door, grip the sides of the door, lift upwards and then slide the door forwards (**Fig.6-5**) and remove.

Fig.6-5

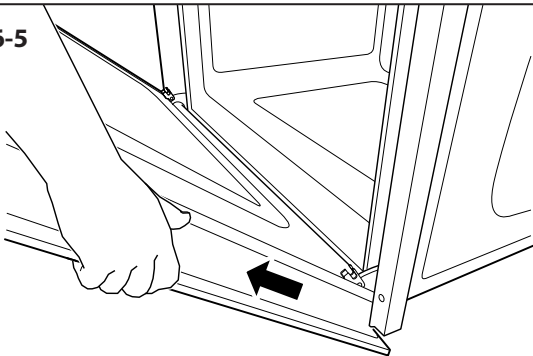

### Removing the storage drawer

Pull the drawer right out.

Push the ends of the plastic clips – down of the left-hand side, up on the right-hand side – to release the catches holding the drawer to the side rails (**Fig.6-6**). At the same time pull the drawer forwards and away from the side rails.

For safety's sake push the drawer rails back out of the way.

For safety's sake push the drawer rails back out of the way. Put the drawer somewhere safe – do not replace it until you have completed the installation, you will need access to the area behind the drawer.

Fig.6-6

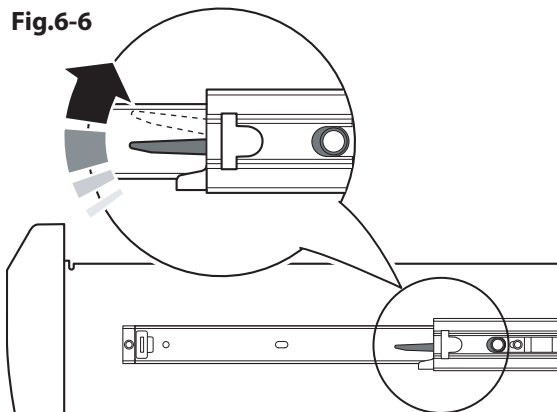

When you have removed the oven door and storage drawer continue as follows:

Fit the leveling tool on the hexagonal adjusting nut (**Fig.6-7**).

Make 10 complete (360°) turns clockwise. This means turning and removing the leveling tool 20 times (**Fig.6-7**).

Make sure you lower BOTH REAR ROLLERS. There are two adjusting nuts, one for each roller, at both the front bottom corners of the range.

Note the rollers are only intended to aid installation – the range should not be moved once it is installed.

Push the range close to its final position, leaving just enough space to get behind it (**Fig.6-8**).

The appliance can be lifted/moved by gripping the top of the oven cavity once the door is removed.

Do not replace the storage drawer yet.

**IMPORTANT: Remove all tape and packaging. Make sure the burner heads are properly seated and level. Take the accessory pack out of the oven. Check to be sure that no range parts have come loose during shipping.**

Fig.6-7

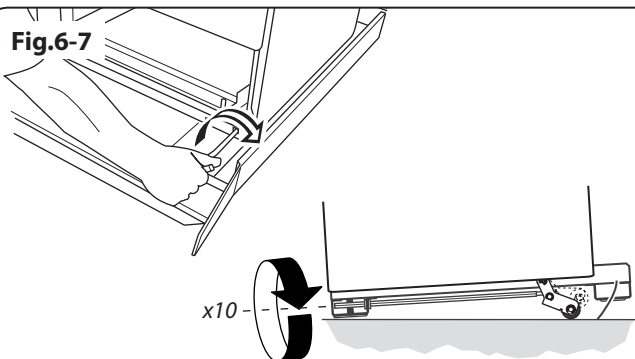

## INSTALLATION

Check the appliance is electrically safe and gas sound when you have finished.

### Installing the Flue Grille

The flue grille is packed separately (**Fig.6-9**).

The larger of the holes along the sides are for screwdriver access and should face to the rear. Use the screws and nuts supplied to hold the grille in place (**Fig.6-10**).

Clip the flexible extensions of the oven flues to the flue grille using the clips provided inside the flue grille (**Fig.6-11**).

### Leveling

It is recommended that you use a spirit level on a shelf in one of the ovens to check for level.

Place the cooker in its intended position, taking care not to twist it within the gap between the kitchen units as damage may occur to the cooker or the units.

The rollers can be adjusted to level the cooker. To adjust the height of the rear of the cooker, use the leveling tool supplied to turn the adjusting nuts at the front bottom corners of the cooker.

The front feet and rear rollers can be adjusted to level the cooker. To adjust the height of the rear of the cooker use the leveling tool supplied to turn the adjusting nuts at the front bottom corners of the cooker. To set the front feet turn the bases to raise or lower.

Leave the leveling tool in the storage drawer, so that the customer can use it if they wish to move the cooker.

### Anti-Tip Device

**WARNING: The range must be secured by the Anti-Tip bracket supplied. Unless properly installed, the range could be tipped by leaning on the door. Injury might result from spilled hot liquids or from the range itself.**

**Note:** The range must be set to the correct height and leveled before the anti-tip bracket is installed.

#### Kit Contents:

- |                               |   |
|-------------------------------|---|
| 1. Anti-Tip bracket base      | 1 |
| 2. Anti-Tip bracket extension | 1 |
| 3. M5 screw                   | 2 |

Assemble the Anti-Tip bracket base and Anti-Tip bracket extension as shown using M5 screws (**Fig.6-12**).

Dimension 'A' should be set to give a clearance of about  $\frac{1}{4}$ " (0.6 cm) above the rear channel of the range base (**Fig.6-13**).

The assembled bracket should be firmly secured to the floor to give a minimum engagement of 2" (5 cm) in the rear channel of the range base. If the range is mounted on a protective sheet make sure the bracket base is firmly attached to the floor not just the sheet (**Fig.6-14**).

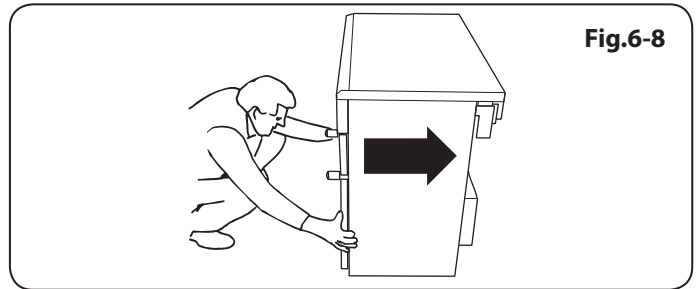

Fig.6-8

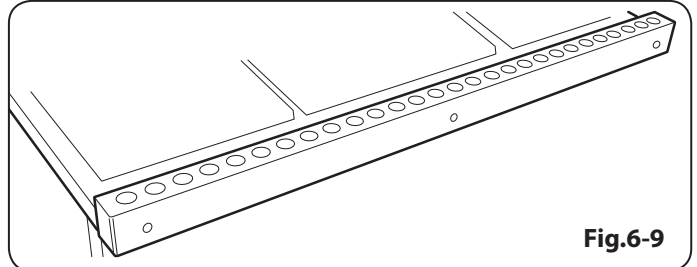

Fig.6-9

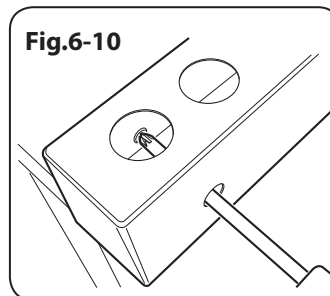

Fig.6-10

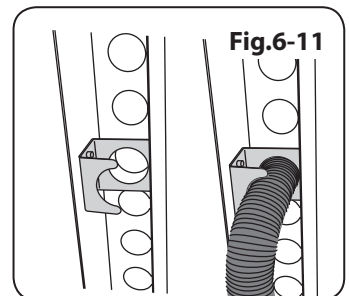

Fig.6-11

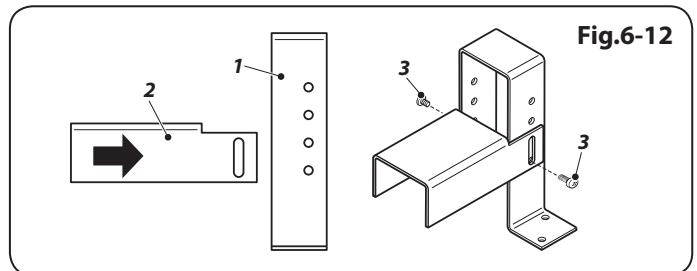

Fig.6-12

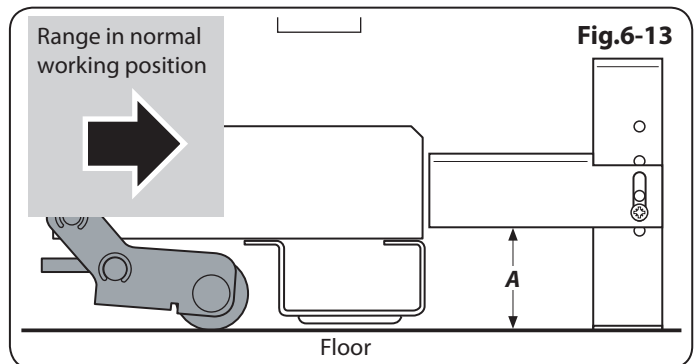

Fig.6-13

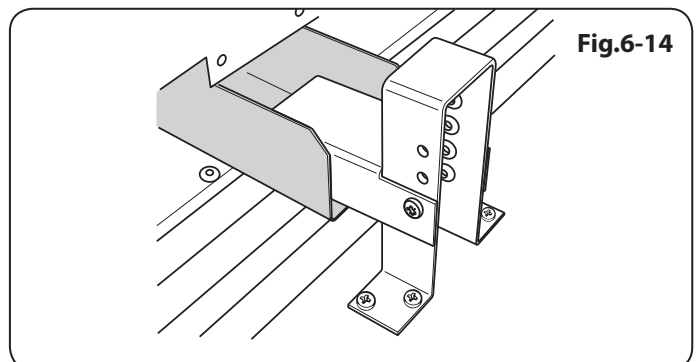
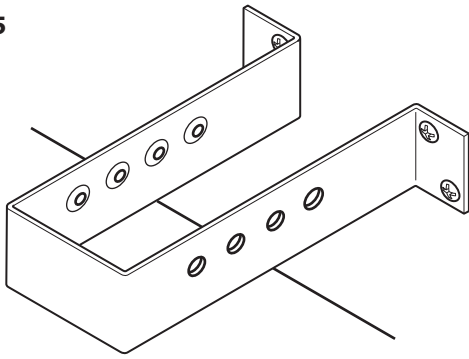

Fig.6-14

## INSTALLATION

Check the appliance is electrically safe and gas sound when you have finished.

Fig.6-15



### Wall Attachment

When floor attachment is impractical you may attach the anti-tip bracket base securely to a solid wall or wall stud (**Fig.6-15**).

For both floor and wall attachment it is essential to use the appropriate fixing screws and to ensure that the Anti-Tip bracket is firmly attached.

### Side Panel Extension kit

Two side extension panels are supplied with the range. These can be installed where the side of the range is exposed. The extension installation must be performed by a qualified gas installer, preferably during installation of the appliance (**Fig.6-16**).

#### Kit Contents:

Side panel extension	2
M5 screw	4
M5 nut	4
Large washer	4
Shakeproof washer	4

#### Procedure

1. Place a screw and washer in the top hole in the rear edge of the range side panel. Add a shakeproof washer and start the nut on the screw threads so that the screw is loosely held in place. Repeat with the other hole (**Fig.6-17**).
2. Slide the side extension in from the side behind the washers (**Fig.6-18**).
3. Tighten the top and bottom screws to hold the side extension in place.

Fig.6-16

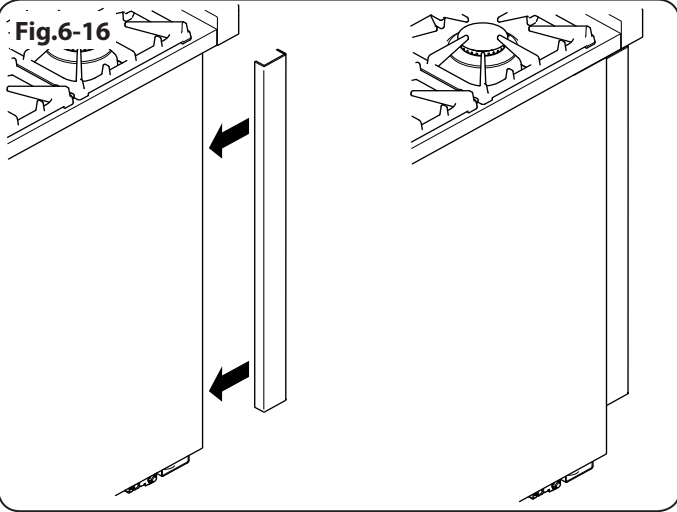

Fig.6-17

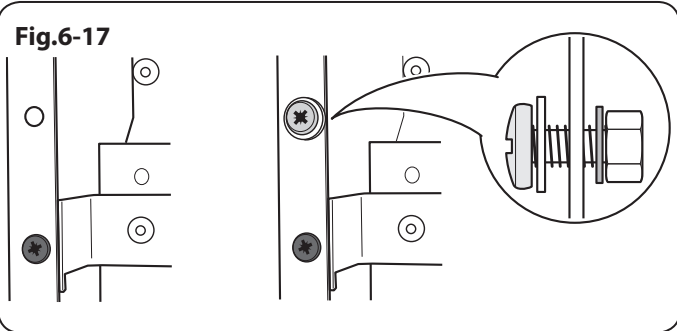
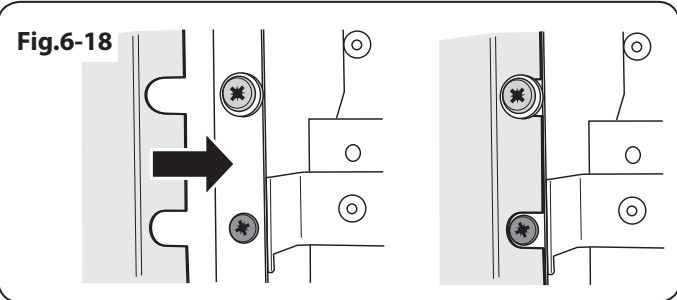

Fig.6-18



## INSTALLATION

Check the appliance is electrically safe and gas sound when you have finished.

### Electrical Connection

When installed the range must be electrically grounded in accordance with local codes or; in the absence of local codes with the National Electrical Code ANSI/NFPA 70, latest edition.

In Canada the range must be installed in accordance with the current CSA Standard C22.1 – Canadian Electrical Code Part 1.

### Electrical Requirements

**⚠ CAUTION**  
For personal safety, do not use an extension cord with this appliance. Remove the house fuse or open the circuit breaker before beginning installation.

This appliance must be supplied with the proper voltage and frequency, and connected to an individual, properly grounded branch circuit, protected by a circuit breaker or time-delay fuse, as noted on the rating plate.

Wiring must conform to National Electric Codes. If the electric service provided does not meet the above specifications, have a licensed electrician install an approved outlet.

Because range terminals are not accessible after range is in position, flexible service conduit or cord must be used.

### Provide Proper Electrical Supply

This range must be supplied with 240 V 60 Hz, and connected to an individual, properly grounded branch circuit protected by a circuit breaker or time-delay fuse (16 amp). If the electrical service provided does not meet the above specifications, it is recommended that a licensed electrician install an approved outlet.

From January 1, 1996, the National Electric Code requires that new construction (not existing) utilize a 4-conductor connection to an electric range.

### Connecting using the supplied cord and plug

Your range is shipped with a 4-prong plug to be used in a NEMA 14-50R receptacle.

### Recommended Electrical Outlet Locations

Locate the electric supply as illustrated (Fig.6-19).

When connecting using a NEMA 14-50R receptacle, if possible position it so that it can be accessed through the opening at the rear of the drawer cavity. The range can then be easily disconnected for servicing, etc.

Plug the range power cord into a properly grounded wall receptacle.

### Connecting if the supplied cord and plug is not suitable

To remove the electrical connection cover (Fig.6-20), remove the screws.

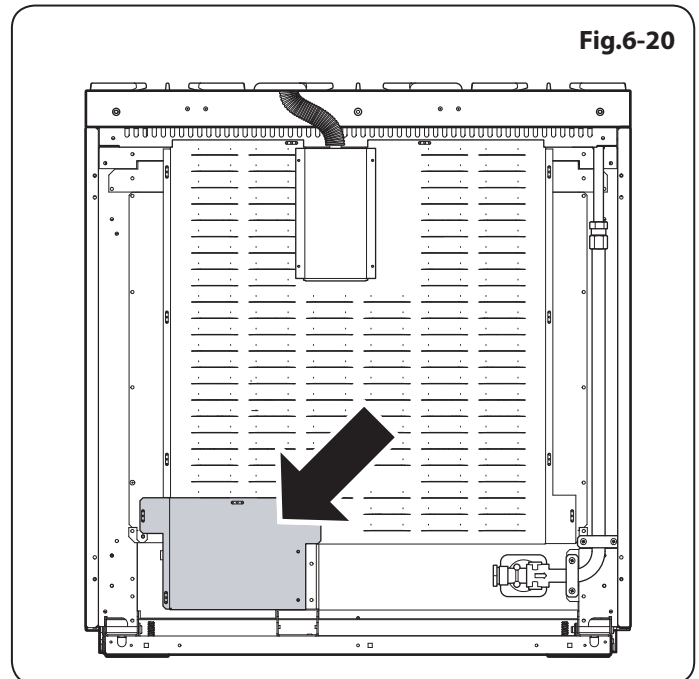
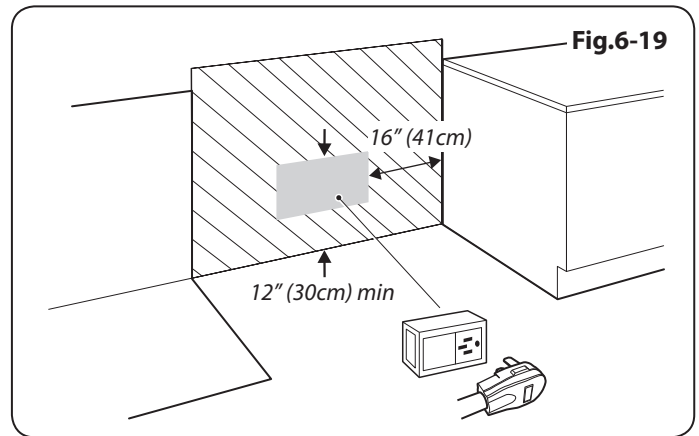

## INSTALLATION

Check the appliance is electrically safe and gas sound when you have finished.

Fig.6-21

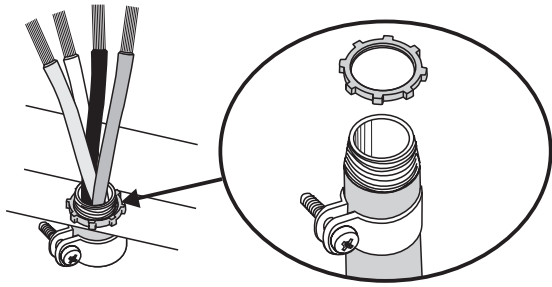

Fig.6-22

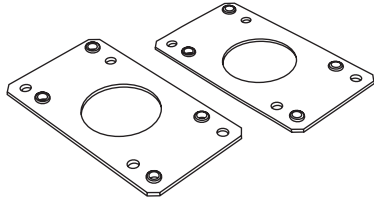

Fig.6-23

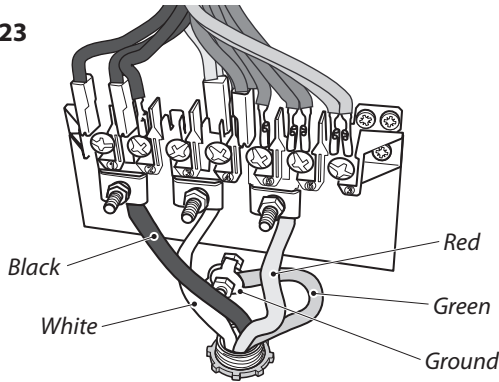

Fig.6-24

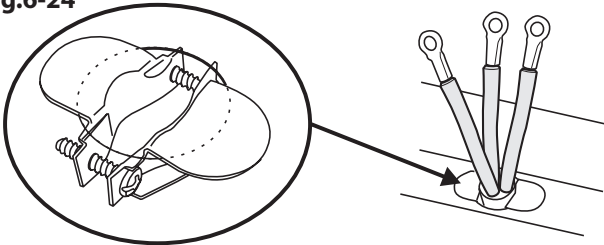

Fig.6-25

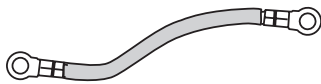
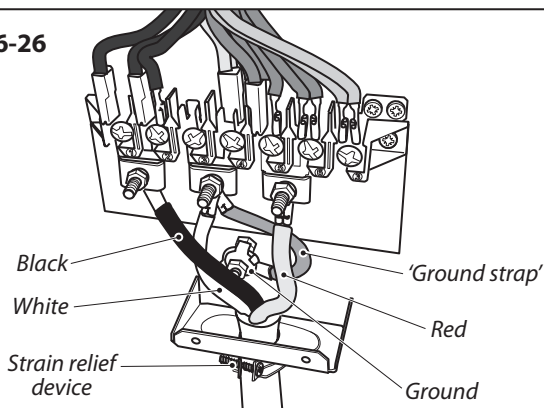

Fig.6-26



### 4-Wire Conduit Installation

Disconnect the supplied power cord from the terminal block and ground post. Keep the terminal block parts; you will need them. Remove the strain relief clamp from the power cord and remove the power cord and strain relief clamp from the mounting bracket (**Fig.6-21**).

The range is shipped with reducer plates to give a 1<sup>1</sup>/<sub>8</sub>" diameter opening for conduit connection. Find the reducer plates (**Fig.6-22**) in the conversion kit and fix them to the mounting bracket.

Attach a squeeze connector (not supplied with the range) to your conduit. Insert the conduit through the reducer plates on the mounting bracket. Allow enough slack to easily attach the wires to the terminal block.

**Note:** Do not install the conduit without a squeeze connector.

Attach the wires to the ground post and terminal block (**Fig.6-23**).

**Note:** Make sure the wires are completely inserted into the terminals and secure connections are made.

Secure the squeeze connector in place in the bracket by tightening the squeeze connector screws.

Replace the electrical connection cover.

### Installing a 3-Wire Power Cord

Disconnect the supplied power cord from the terminal block and ground post. Keep the terminal block parts; you will need them. Remove the strain relief clamp from the power cord and remove the power cord and strain relief clamp from the mounting bracket. Discard the strain relief clamp.

**Note:** Do not install the power cord without a strain relief – use the clamp supplied with the cord.

Install the new strain relief device to the mounting bracket by removing the two clamping screws, feeding the two halves (ears first) through the hole in the mounting bracket and loosely replacing the screws. Insert the power cord through the strain relief device but do not tighten the device yet (**Fig.6-24**).

A ground strap is supplied in the conversion pack (**Fig.6-25**).

Attach the ground strap to the ground and center terminal of the connector block (**Fig.6-26**).

The neutral or ground wire of the power cord must be connected to the neutral terminal located in the center of the connector block. The power leads must be connected to the outside terminals.

Make sure the connections are tight. Now tighten the strain relief device to clamp the power cord.

Refit the electrical connection cover.

## INSTALLATION

Check the appliance is electrically safe and gas sound when you have finished.

### 3-Wire Conduit Installation

Disconnect the supplied power cord from the terminal block and ground post. Keep the terminal block parts; you will need them. Remove the strain relief clamp from the power cord and remove the power cord and strain relief clamp from the mounting bracket.

The range is shipped with reducer plates to give a  $1\frac{1}{8}$ " diameter opening for conduit connection. Find the reducer plates (**Fig.6-27**) in the conversion kit and fix them to the mounting bracket.

Install a squeeze connector (not supplied with the range), to your conduit. Insert the conduit through the reducer plates on the mounting bracket. Allow enough slack to easily attach the wires to the terminal block (**Fig.6-28**).

**Note:** Do not install the conduit without a squeeze connector.

Attach the ground strap to the ground and center terminal of the connector block (**Fig.6-29**).

The neutral or ground wire of the power cord must be connected to the neutral terminal located in the center of the connector block. The power leads must be connected to the outside terminals.

**Note:** Make sure the wires are completely inserted into the terminals and secure connections are made.

Secure the squeeze connector in place in the bracket by tightening the squeeze connector screws.

Fig.6-27

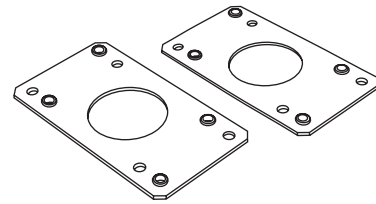

Fig.6-28

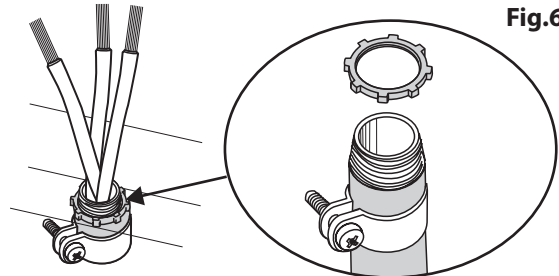
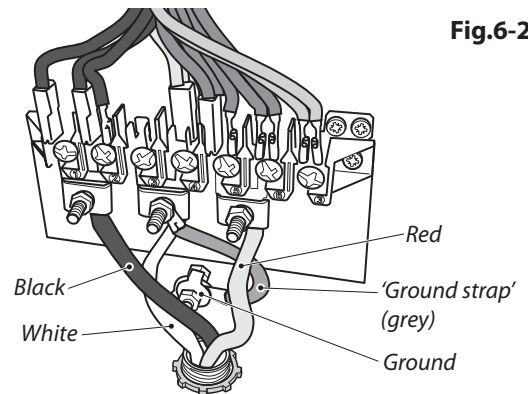

Fig.6-29



## INSTALLATION

Check the appliance is electrically safe and gas sound when you have finished.

Fig.6-30

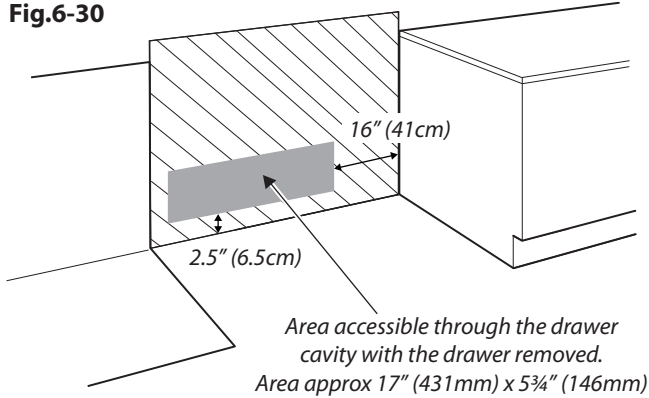

Fig.6-31

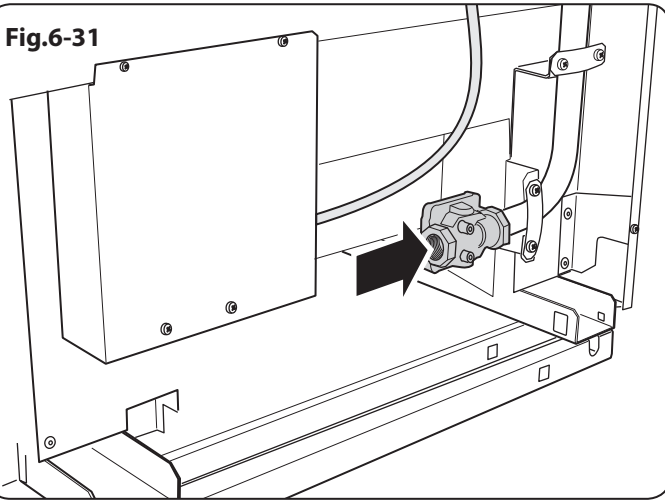
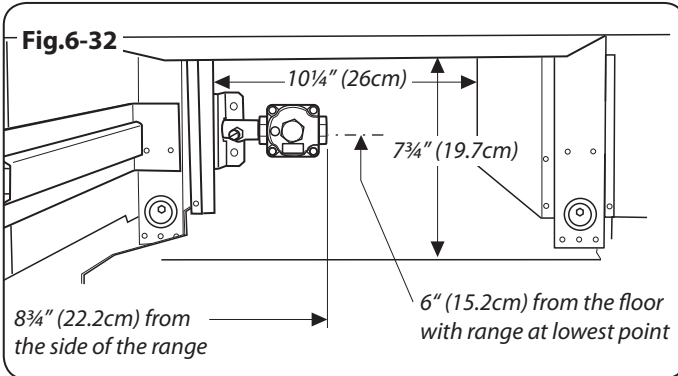

Fig.6-32



### Gas Connection

Installation of this range must conform with local codes or, in the absence of local codes, with the National Fuel Gas Code, ANSI Z223.1-latest edition.

#### *In Canada*

The range must be installed in accordance with the current CGA Standard CAN/CGA-B149 – Installation Codes for Gas Burning Appliances and Equipment and/or local codes.

#### *In The Commonwealth Of Massachusetts*

This product must be installed by a licensed plumber or gas fitter when installed within the Commonwealth of Massachusetts.

A "T" handle type manual gas valve must be installed in the gas supply line to this appliance.

### Gas Supply Requirements

Recommended gas pipe outlet locations are shown in Fig.6-30, Fig.6-31 and Fig.6-32.

### Provide Adequate Gas Supply

Prior to installation, ensure that the local distribution conditions (nature of the gas and gas pressure) and the adjustment of the appliance are compatible.

The range is designed to operate at a manifold pressure of 4" of water column (1 kPa) on natural gas. A conversion kit for LP gas (Propane) is supplied with the range. When converted to LP gas, a pressure of 10" of water column (2.49 kPa) is required.

Make sure you are supplying your range with the correct type of gas.

If the range is to be used on LP gas, a qualified LP installer must convert it. We recommend that the range be converted before installation. This must be done before the range can be used on LP gas.

For proper operation, the pressure of natural gas supplied to the regulator must be between 4 1/2" and 13" of water column (1.12–3.24 kPa).

For LP gas, the pressure supplied must be between 10" and 13" of water column (2.49–3.24 kPa).

When checking for proper operation of the regulator, the inlet pressure must be at least 1" (0.25 kPa) greater than the operating (manifold) pressure as given above.

The pressure regulator located at the inlet of the range manifold must remain in the supply line regardless of whether natural or LP gas is being used.

A flexible metal appliance connector used to connect the range to the gas supply line should have an I.D. of 1/2" and be 5 feet in length for ease of installation.

## INSTALLATION

Check the appliance is electrically safe and gas sound when you have finished.

### Connect the Range to the Gas Supply

Shut off the main gas supply valve before disconnecting the old range and leave it off until the new hookup has been completed. Don't forget to relight the pilot on other gas appliances when you turn the gas back on.

Because hard piping restricts movement of the range, the use of a CSA International-certified flexible metal appliance connector is recommended unless local codes require a hard-piped connection.

Never use an old connector when installing a new range. If the hard piping method is used, you must carefully align the pipe; the range cannot be moved after the connection is made.

To prevent gas leaks, put pipe joint compound on, or wrap pipe thread tape with Teflon\* around, all male (external) pipe threads.

- A.** Install a manual gas line shut-off valve in the gas line in an easily accessed location outside of the range. Make sure everyone operating the range knows where and how to shut off the gas supply to the range.
- B.** Install a male  $\frac{1}{2}$ " flare union adapter to the  $\frac{1}{2}$ " NPT internal thread elbow at inlet of regulator. Use a backup wrench on the regulator fitting to avoid damage. When installing the range from the front, remove the 90° elbow for easier installation.
- C.** Install male  $\frac{1}{2}$ " or  $\frac{3}{4}$ " flare union adapter to the NPT internal thread of the manual shut-off valve, taking care to backup the shut-off valve to keep it from turning.
- D.** Connect flexible metal appliance connector to the adapter on the range. Position the range to permit connection at the shut-off valve.
- E.** When all connections have been made, make sure all range controls are in the off position and turn on the main gas supply valve. Use a liquid leak detector at all joints and connections to check for leaks in the system. Use a product specifically manufactured for leak detection. Leak testing of the appliance shall be conducted in accordance to the manufacturer's instructions.

#### **⚠ CAUTION: DO NOT use a flame to check for gas leaks.**

When using test pressures greater than  $\frac{1}{2}$  psig (3.5 kPa) to pressure test the gas supply system of the residence, disconnect the range and individual shut-off valve from the gas supply piping. When using test pressures of  $\frac{1}{2}$  psig (3.5 kPa) or less to test the gas supply system, simply isolate the range from the gas supply system by closing the individual shut-off valve.

### Flexible Connector

Installer: Inform the consumer of the location of the gas shut-off valve (**Fig.6-33**).

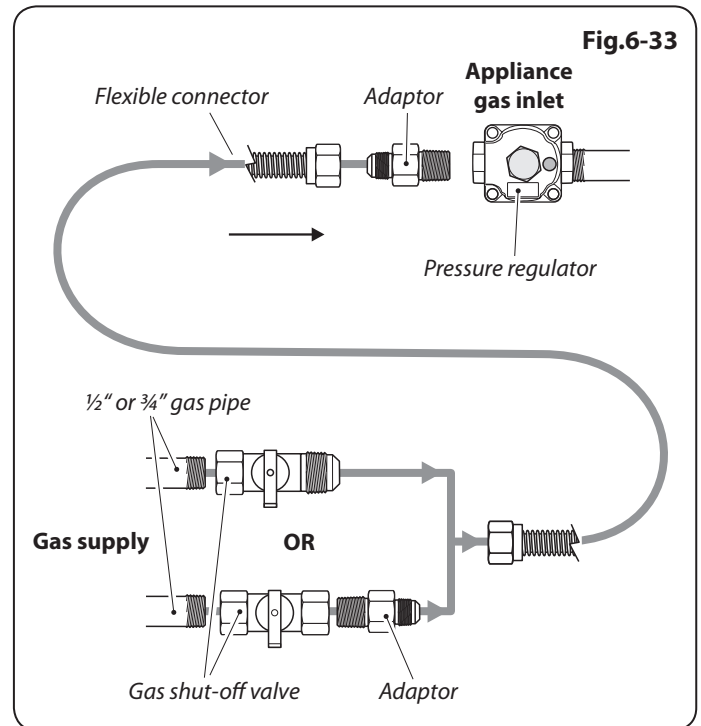

\*Teflon: Registered trademark of DuPont

## INSTALLATION

**Check the appliance is electrically safe and gas sound when you have finished.**

**Fig.6-34**

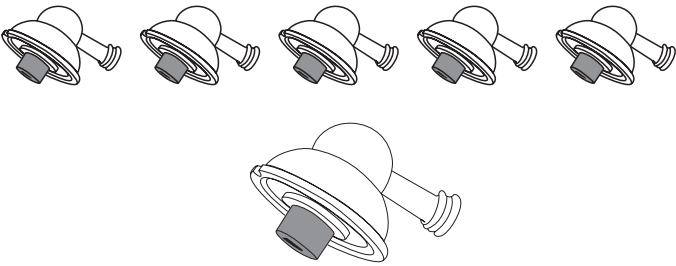

### Seal the Openings

Seal any openings in the wall behind the range and in the floor under the range when hookups are completed.

**IMPORTANT:** When all connections are completed make sure the flow of combustion and ventilation air to the range is unobstructed.

### Leveling

Place the range in its intended position taking care not to twist it within the gap between the kitchen units as damage may occur to the range or the units. Install the oven racks in the oven. Check for levelness by placing a level or a cup, partially filled with water, on one of the oven grids. If using a spirit level, take two readings with the level placed diagonally first in one direction and then the other.

The rollers can be adjusted to level the range. To adjust the height of the rear of the range use the leveling tool supplied to turn the adjusting nuts at the front bottom corners of the range.

**Fig.6-35**

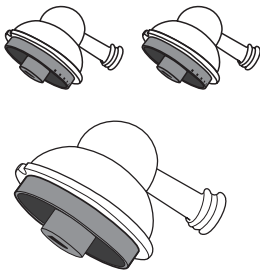

### Assemble the Range

#### Installing the Control Knobs

The range is supplied with 5 burner control knobs. These are for the gas controls to the left of the control panel (**Fig.6-34**).

There are also 2 oven control knobs (**Fig.6-35**).

Push the multi-function oven selector knob and temperature knob on to the control spindles at the right hand side of the control panel.

**Fig.6-36**

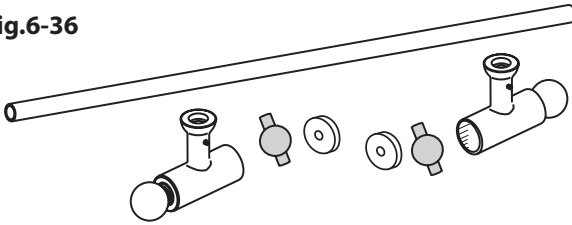

#### Installing the Handrail

##### Components (Fig.6-36)

Hand rail tube	1
End cap with Allen fixing screw	2
Plastic friction cup	2
White plastic disk	2

Hold a friction cup by the tabs on one end of the tube (**Fig.6-37**). Add one of the white plastic disks (**Fig.6-38**).

Line up one of the end caps to the tube and push it on the tube over the friction cup and disk (**Fig.6-39**).

Turn the tube over and push on the other end cap using the second friction cup and disk, making sure that you do not scratch or damage the first end piece and that the two end pieces are lined up correctly.

Install the assembled handrail on the projecting mounting studs on the control panel and hold it in place by tightening the Allen screws. The Allen screws should be on the underside (**Fig.6-40**).

**Fig.6-37**

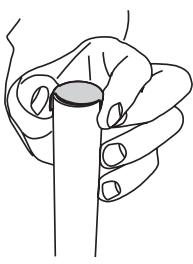

**Fig.6-38**



**Fig.6-39**

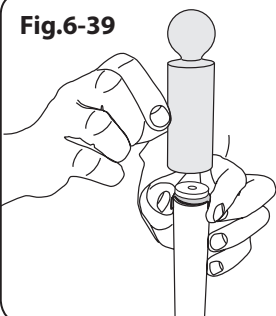

**Fig.6-40**

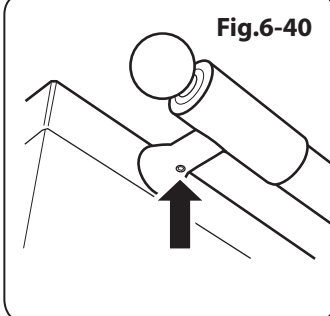

**Fig.6-41**

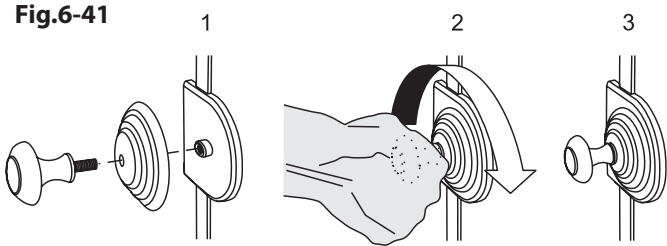

#### Installing the Door Handle

Assemble the door knob to the door knob base and screw it to the mounting on the oven door. Hand tighten only – do not use any tools (**Fig.6-41**).

## INSTALLATION

Check the appliance is electrically safe and gas sound when you have finished.

### Installing the Toe Kick

Remove the 3 screws for the toe kick mounts along the front bottom edge of the range. Fasten the toe kick using these screws (alternative color screws can be found in the loose parts pack).

### Fitting the Grates

Make sure that the grates are in the correct position and sitting down (**Fig.6-42**).

### Replace the Storage Drawer

To replace the drawer in the range, pull the side rails fully out (**Fig.6-43**).

At each side, hold the front of the drawer and pull the side rail forward so that the clips click into position, holding the drawer to the side rails.

### Refitting the Oven Door

To refit the door, slide the hinges back into their slots. Rotate the locking 'U' clips back to fit onto the hinges.

Fig.6-42

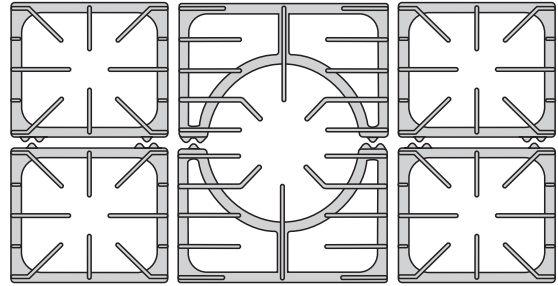
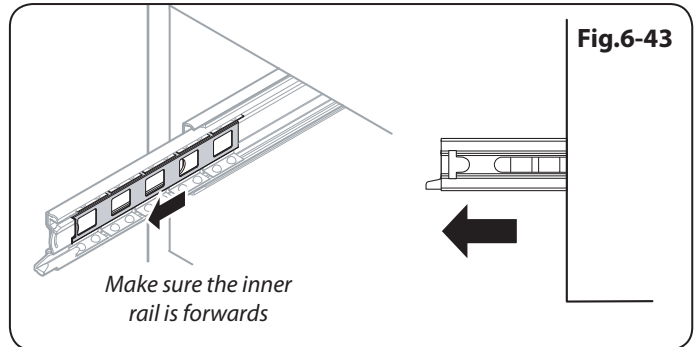

Fig.6-43



## INSTALLATION

Check the appliance is electrically safe and gas sound when you have finished.

### Range operational checks

#### Oven Check

Turn on the oven and check that the oven fans start to turn and that the oven starts to heat up. Turn off the oven.

#### Oven Light

Press the oven light switch and check that the lights are working.

**Note:** The oven light bulbs are not included in the warranty.

#### Check Ignition of Cooktop Burners

Operation of all cooktop burners should be checked after the range and gas supply lines have been carefully checked for leaks.

Check each burner in turn. There is a flame safety device that stops the flow of gas to the burner if the flame goes out. There is also a spark ignition system that works when the knob is pressed in.

For each burner, push in and turn a knob to the lighting position.

The igniter should spark and light the gas. Keep holding the knob pressed in to let the gas through to the burner for few seconds.

If, when you let go of the control knob, the burner goes out, the safety device has not held in. Turn the control to the off position and wait one minute, then try again this time holding in the control knob for slightly longer.

#### Quality of Flames

If the flame is distorted, check that the burner head is correctly placed over the burner base.

**⚠ MAKE SURE THE FLOW OF COMBUSTION AND VENTILATION AIR TO THE RANGE IS UNOBSTRUCTED.**

**⚠ MAKE SURE ALL CONTROLS ARE LEFT IN THE OFF POSITION.**

### Customer Care

Please complete your details in the table at the end of the 'Using your Range' section of this Guide.

Please inform the user how to operate the range. Place these instructions into the colored CornuFé folder in the instruction pack and hand them to the user.

**Thank you.**

### How To Move the Range for Servicing

Follow these procedures to remove appliance for servicing:

- Shut off the gas supply and turn off the circuit breaker.
- Disconnect gas supply tubing to appliance and unplug the electrical supply cord.

**Note:** A suitably qualified person should disconnect and reconnect the gas supply.

The range is very heavy. Take great care. We recommend two people maneuver the range. Ensure that the floor covering is firmly attached, or removed to prevent it being disturbed when moving the range around. You will need the leveling tool.

Before attempting to move the range, see 'Moving the Range' on page 24.

### Replacing the Range

Reverse procedure to reinstall. If gas line has been disconnected, check for gas leaks after reconnection.

**Note:** A suitably qualified person should disconnect and reconnect the gas supply.

The service engineer MUST follow installation instructions provided with the gas appliance connector and the warning label attached to the connector.

If the range is removed for any reason, make sure the anti-tip device is re-engaged properly when the range is replaced. Failure to take this precaution could result in tipping of the range and cause injury.

Replace the storage drawer and door.

# WARNING!

If the information in this manual is not followed exactly, a fire or explosion may result causing property damage, personal injury or death.

**Do not store or use gasoline or other flammable vapors and liquids in the vicinity of this or any other appliance.**

## WHAT TO DO IF YOU SMELL GAS

**Do not try to light any appliance.**

**Do not touch any electrical switch.**

**Do not use any phone in your building.**

**Immediately call your gas supplier from a neighbor's phone. Follow the gas supplier's instructions.**

**If you cannot reach your gas supplier, call the fire department.**

**Installation and service must be performed by a qualified installer, service agency or the gas supplier.**

# WARNING!

The anti-tip device supplied with this range must be installed when the appliance is installed. This will reduce risk of tipping of the appliance from abnormal usage or by excessive loading of the oven door or storage drawer.

	<b>⚠ WARNING</b>
	<ul style="list-style-type: none"><li>• ALL RANGES CAN TIP</li><li>• INJURY TO PERSONS COULD RESULT</li><li>• INSTALL ANTI-TIP BRACKET PACKED WITH RANGE</li><li>• SEE INSTALLATION INSTRUCTIONS</li></ul>

## INSTALLATION

Check the appliance is electrically safe and gas sound when you have finished.

# 7. Conversion to LP Gas

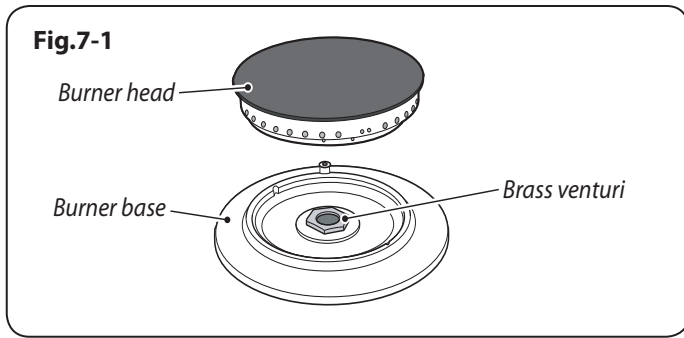

	Natural Gas	Propane Gas
Center burner	205	118
Large Burners	150	99
Right front burner	112	68

Table 7-1

## Important

- Observe all governing codes and ordinances.
- The range must be properly grounded.
- Save these instructions for the local electrical inspector's use.

When servicing or replacing gas carrying components disconnect from gas before commencing operation and check appliance is gas sound after completion. When checking for gas leaks use a liquid leak detector at all joints and connections to check for leaks in the system. Use a product specifically manufactured for leak detection. Leak testing of the appliance shall be conducted in accordance to the manufacturer's instructions.

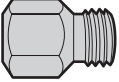
## For Your Safety

DO NOT store or use combustible materials, gasoline or other flammable vapors and liquids in the vicinity of this or any other appliance.

## Conversion to Propane

This appliance is supplied set for Natural gas. A conversion kit for Propane gas is supplied with the range.

If the appliance is to be converted this must be done before installation. The conversion must be performed by a qualified LP gas installer. After conversion the installation must comply with the relevant regulations and also the local electricity supply company requirements. Read the instructions before converting this appliance.

Failure to convert the appliance correctly could invalidate any warranty or liability claims and lead to prosecution.

This instruction must be used in conjunction with the rest of the appliance instruction, in particular for information on Standards, range positioning, connection hose suitability etc.

When servicing or replacing gas-carrying components disconnect from gas before commencing operation and check appliance is gas sound after completion.

DO NOT use reconditioned or unauthorized gas controls.

## Orifices

Remove the burner heads. Undo the large brass nuts and remove the brass venturis and rings (**Fig.7-1**).

### Either:

Use a long socket wrench to access and remove the old orifices.

### Or:

Lift up the front of the maintop and prop it up at the front. Remove the old orifices.

Save the orifices removed from the appliance for future use. Install the new orifices; see **Table 7-1** for orifice details.

## INSTALLATION

**Check the appliance is electrically safe and gas sound when you have finished.**

Replace the rings on the burners. Screw in the hexagon headed venturi to make fitting the burners easier. Do not tighten yet.

When all the burner bases and venturis have been fitted tighten the venturi nuts.

### Valve adjustment

Pull off all the control knobs.

Open both oven doors and remove the fixing screws underneath the control panel.

On single oven models the cooling guide, below the control panel, and its 4 fixing screws must be removed to gain access to the control panel fixings.

Remove the 3 fixing screws at the top of the control panel.

Pull the control panel forward. Taking care not to damage it, by protecting it with cloth for example, rest it on the open oven doors.

### To convert the control valves

Unscrew the control valve bypass screw (**Fig.7-2**). Using a pair of long nose pliers, carefully remove the bypass screw (**Fig.7-3**).

Install the correct replacement screw. See **Table 7-2** for the correct size. Tighten the screw down.

### Valve Bypass screws

Save the removed bypass screws for possible future reversion to Natural gas.

### Reassemble

Replace the control panel and secure with fixing screws.

Refit the control panel and cooling guide where fitted

If you have lifted the maintop, carefully lower it onto the range. The burners are protected against the burner flames going out by Flame safety devices (FSD's).

Take care when lowering the maintop to locate the FSD sensor probes (**Fig.7-4**) in their holes in the cook top and the burner bases.

### Gas Regulator

Pull the drawer right out.

Push the ends of the plastic clips – down of the left-hand side, up on the right-hand side – to release the catches holding the drawer to the side rails (**Fig.7-5**). At the same time pull the drawer forwards and away from the side rails.

For safety's sake push the drawer rails back out of the way.

The regulator is now accessible.

The regulator may be one of two types (**Fig.7-6**).

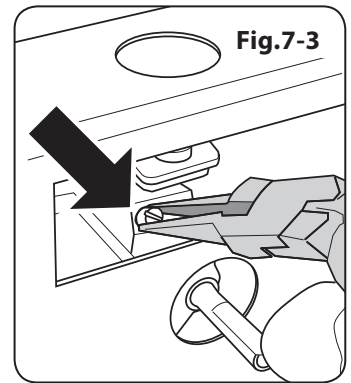
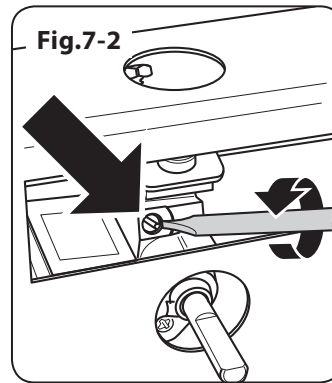

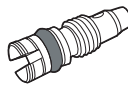
	Natural Gas	Propane Gas
<b>Hotplate</b>	Bypass	Bypass
<b>Center burner</b>	82	49
<b>Large burners</b>	70	38
<b>Right front burner</b>	53	31

**Table 7-2**

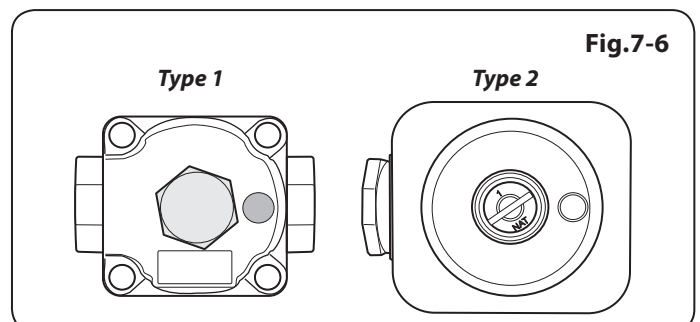
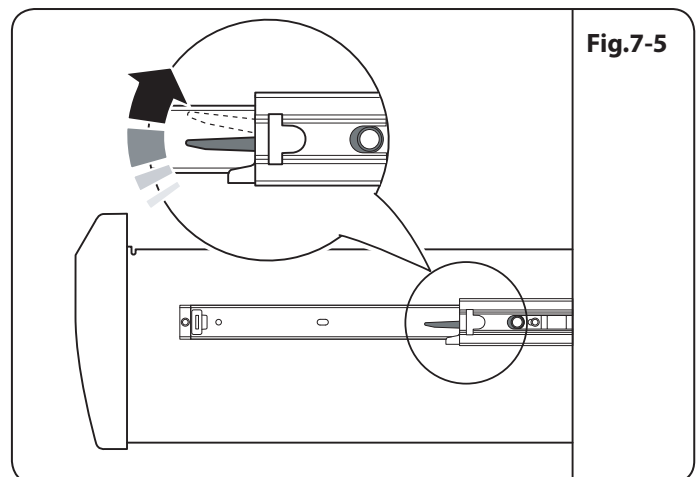
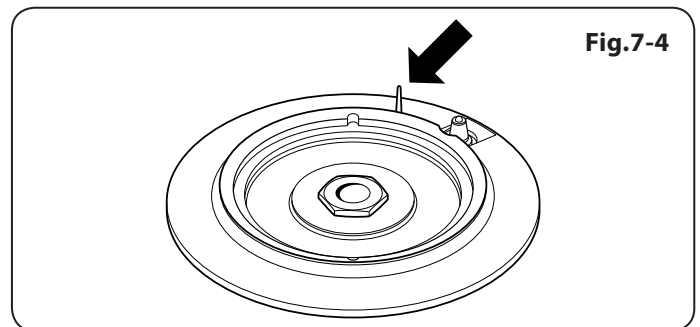

## INSTALLATION

Check the appliance is electrically safe and gas sound when you have finished.

Fig.7-7

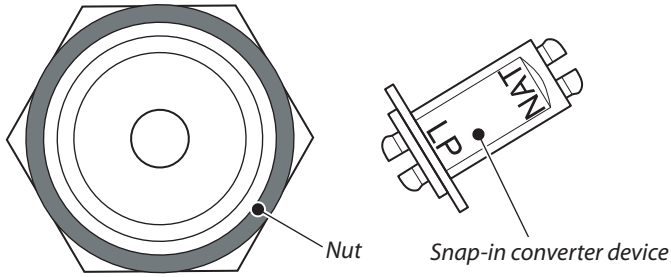

### Type 1

Unscrew the hexagonal nut in the front of the regulator. The regulator nut has a plastic snap-in converter device on the underside (**Fig.7-7**). To convert the regulator snap the device out of the nut and replace the other way up.

The snap-in converter device is marked to show which gas it is set for (**Fig.7-8**). Make sure the device is secure in the base of the nut and replace the nut to the regulator.

### Type 2

The regulator has a bayonet mounted top cap (**Fig.7-9**).

Using a small coin, press in and turn the cap to remove it.

Turn the cap over so that the letters "LP" are visible on base of the hollow in the cap. Replace the cap making sure that the bayonet pins are securely located (**Fig.7-10**).

Fig.7-8

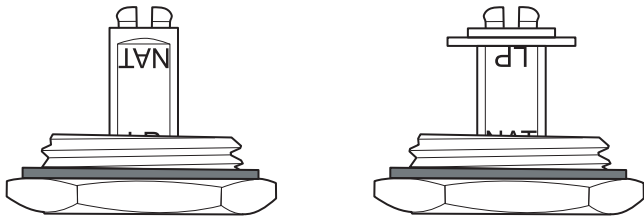

### Stick on Label

Stick the "NOW ADJUSTED FOR LP GAS" label next to the ratings label inside the drawer cavity to indicate the gas the appliance is now set for (**Fig.7-11**).

Fig.7-9

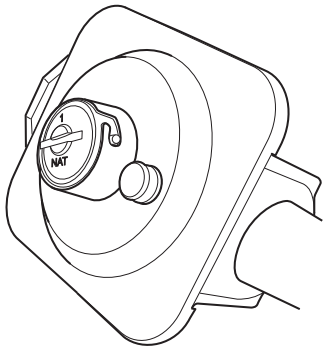

### Pressure Testing

Connect the appliance to the gas supply. Check the appliance is gas sound.

The gas pressure can be measured at the pressure test point on the appliance side of the pressure regulator (**Fig.7-12**).

For proper operation, the pressure of LP supplied to the regulator must be between 10" and 13" of water column (2.49 - 3.24 kPa).

When checking for proper operation of the regulator, the inlet pressure must be at least 1" (0.25 kPa) greater than the operating (manifold) pressure as given above.

The pressure regulator located at the inlet of the range manifold must remain in the supply line regardless of whether natural or LP gas is being used.

Fig.7-10 Type 1

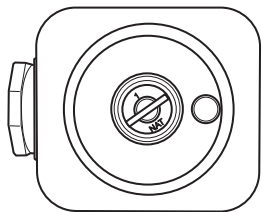

Type 2

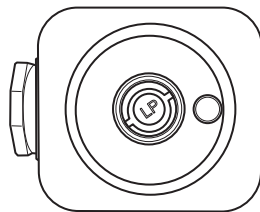
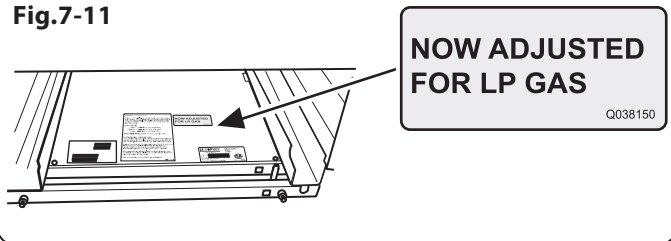

Fig.7-11



## INSTALLATION

Check the appliance is electrically safe and gas sound when you have finished.

### Replace the storage drawer

To replace the drawer in the range, pull the side rails fully out (Fig.7-13).

At each side, hold the front of the drawer and pull the side rail forward so that the clips click into position, holding the drawer to the side rails.

**⚠ Check the appliance is gas sound.**

**⚠ CAUTION: DO NOT use a flame to check for gas leaks.**

When using test pressures greater than  $\frac{1}{2}$  psig to pressure test the gas supply system of the residence, disconnect the range and individual shut-off valve from the gas supply piping. When using test pressures of  $\frac{1}{2}$  psig or less to test the gas supply system, simply isolate the range from the gas supply system by closing the individual shut-off valve.

**⚠ Check the operation of all the burners.**

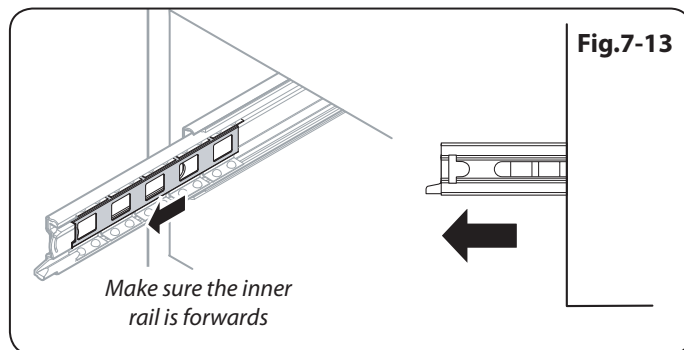
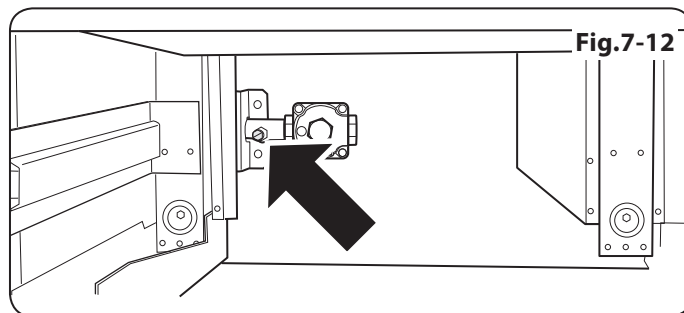

## 8. Service and Parts

Please complete the appliance details opposite and keep them safe for future reference - this information will enable us to accurately identify your particular appliance and help us to help you. Filling this in now will save you time and inconvenience if you later have a problem with your appliance. It may also be of benefit to keep your purchase receipt with this leaflet. You may be required to produce the receipt to validate a warranty service visit.

This information is on the appliance data badge. This is located inside base of drawer cavity. For removal of the drawer see the 'Storage' section of the instructions.

### If you have a problem

In the unlikely event that you have a problem with your appliance please refer to the rest of this booklet, especially the 'Troubleshooting' section, first to check that you are using the appliance correctly.

If you are still having difficulty, contact:

#### La Cornue Service Center

**Phone: 877-LACORNUE (7:00 am - 4:00 pm M-F Pacific time).**

### Please note

If your appliance is outside the 3 year warranty period our service provider may charge for this visit.

If you request an engineer to visit and the fault is not the responsibility of the manufacturer, our service provider reserves the right to make a charge.

Appointments not kept by you may be subject to a charge.

### Out of Warranty

We recommend that our appliances are serviced regularly throughout their life to maintain the best performance and efficiency.

Service work should only be carried out by technically competent and suitably qualified personnel.

### Parts

To maintain optimum and safe performance, only use genuine parts. Do not use re-conditioned or unauthorized gas controls. Contact your retailer.

<b>Fuel Type</b>
<b>Name of Appliance</b>
<b>Color*</b>
<b>Appliance Serial Number</b>
<b>Retailers Name &amp; Address</b>
<b>Date of Purchase</b>
<b>Installer's Name &amp; Address</b>
<b>Date of Installation</b>

# 9. Circuit Diagram

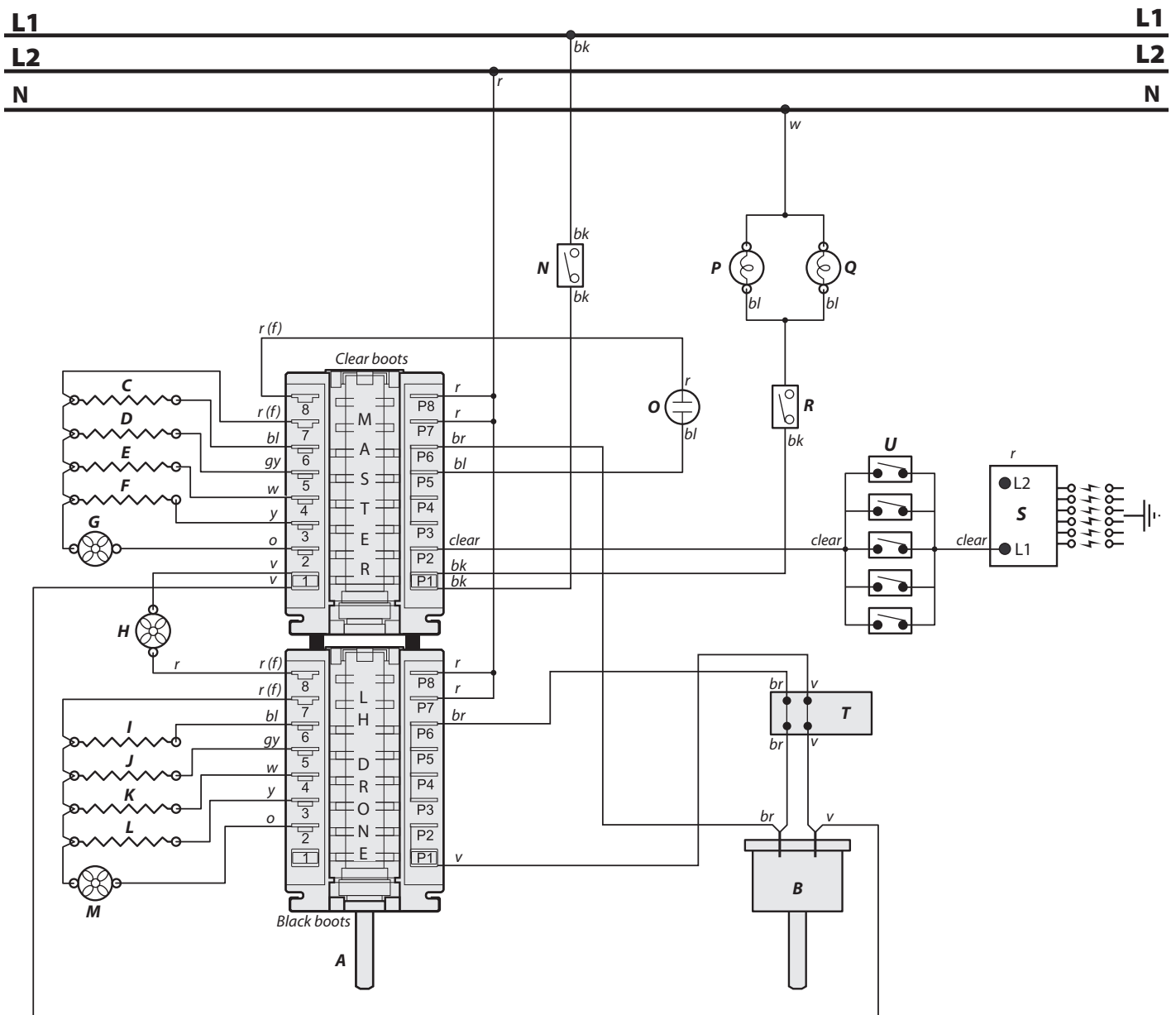

Code	Description
A	Function controller
B	Temperature controller
C	Right-hand bottom element
D	Right-hand top element (outer)
E	Right-hand top element (inner)
F	Right-hand fan element
G	Right-hand fan
H	Cooling fan
I	Left-hand bottom element
J	Left-hand top element (outer)
K	Left-hand top element (inner)

Code	Description
L	Left-hand fan element
M	Left-hand fan
N	Thermostat protection
O	Oven neon
P	Oven light
Q	Oven light
R	Oven light switch
S	Spark generator
T	Divider switch
U	Tap switches

Color Code	
bl	Blue
br	Brown
bk	Black
or	Orange
r	Red
v	Violet
w	White
y	Yellow
g/y	Green/yellow
gr	Grey
r(f)	Red (flag)

## 10. Technical Data

**INSTALLER:** Please leave these instructions with the user.

**DATA BADGE LOCATION:** Inside base drawer of cavity. Remove the drawer (see *Overview > Storage for details*).

**COUNTRY OF DESTINATION:** USA/Canada

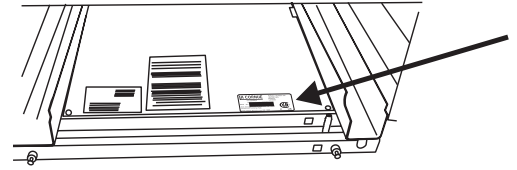

### Connections

<b>Electric</b>	240 V 60 Hz
<b>Gas</b>	½" NPT at rear left-hand side

### Dimensions

<b>Overall height</b>	minimum 35 <sup>15</sup> / <sub>16</sub> " (91 cm)	maximum 36 <sup>7</sup> / <sub>8</sub> " (93.7 cm)
<b>Overall width</b>	35½" (90 cm); see 'Positioning of Cooker'.	
<b>Overall depth</b>	28 <sup>5</sup> / <sub>8</sub> " (720 mm)	
<b>Minimum space for cooktop</b>	31½" (800 mm)	

### Ratings

Oven	
Fan element (x2)	1.8 kW each
Top element (x2)	0.75 kW each
Browning element (x2)	1.15 kW each
Bottom element (x2)	0.75 kW each

Gas Hob					
	Input	Natural gas 4" WC		Propane gas 10" WC	
		Orifice	Screw	Orifice	Screw
Center burner	17,500 btu/hr	205	82	118	49
Large burner	12,500 btu/hr	150	70	99	38
Right-hand front burner	6,000 btu/hr	112	53	68	31

### Efficiencies

Oven	
Energy efficiency class on a scale of A (more efficient) to G (less efficient)	A
Energy consumption based on standard load	0.90 kWh
Usable volume (cubic feet)	3.8
Size	Large
Time to cook standard load	44 minutes

Maximum total electric load 240 V = 3.85 kW, 16 A (including oven fans, lights, etc.)

**Note:** The maximum input at any time is given as the fanned grill, which is all top elements and the fan.

# 11. Warranty

---

## Full Three Year Warranty

Covers three years from the date of installation or date of occupancy for a new previously unoccupied dwelling.

Save your dated receipt or other evidence of the installation/occupancy date.

## La Cornue Will Pay For:

All repair labor and replacement parts found to be defective due to materials and workmanship.

Any damage due to transit must be reported within 15 days of delivery.

Cosmetic faults must be reported within 30 days of installation.

Service must be provided by an Authorized Service Agency during normal working hours.

For a Service Agency nearest you, please call 877-LACORNUE (7:00 am - 4:00 pm M-F Pacific time).

## La Cornue will not pay for:

1. Service by an unauthorized agency or damage or repairs due to service by an unauthorized agency or use of unauthorized parts.
2. Service visits to:
  - Teach you how to use the appliance.
  - Correct the installation. You are responsible for providing electrical wiring and other connecting facilities.
  - Reset circuit breakers or replace home fuses.
  - Replace owner-accessible light bulbs.
3. Damage caused from accident, alteration, misuse, abuse, improper installation or installation not in accordance with local electrical codes or plumbing codes, or improper storage of the appliance.
4. Repairs due to other than normal home use.
5. Service labor during limited warranty period.
6. Travel fees and associated charges incurred when the product is installed in a location with limited or restricted access, (i.e., airplane flights, ferry charges, isolated geographic regions).

Warranty applies to appliances used in residential application: it does not cover their use in commercial installations.

This warranty is for products purchased and retained in the 50 states of the USA, District of Columbia and Canada. Should the appliance be sold by the original purchaser during the warranty period, the new owner continues to be protected until the expiration date of the original purchaser's warranty period.

The warranty applies even if you should move.

LA CORNUE DOES NOT ASSUME ANY RESPONSIBILITY FOR INCIDENTAL OR CONSEQUENTIAL DAMAGES.

Some states do not allow the exclusion or limitation of incidental or consequential damages, so the above limitation or exclusion may not apply to you. This warranty gives you specific legal rights and you may also have other rights that may vary from state to state or province to province.

**If you need service, first see the 'Troubleshooting' section of the instruction book. Additional help can be found by checking the 'Service and Parts' section.**



L a C o r n u e 1 9 0 8

Ateliers La Cornue

14 rue du Bois du Pont

Z.I. les Béthunes

95310 Saint-Ouen l'Aumône

FRANCE

Tél. : + 33 (0)1 34 48 36 36 - Fax : + 33 (0)1 34 64 32 65

E-mail : [a.table@la-cornue.com](mailto:a.table@la-cornue.com)

[www.la-cornue.com](http://www.la-cornue.com)